



**WORLD'S BEST
ALLOY BULLBARS**

East Coast Bullbars (ECB Pty Ltd)

Tel: 07 3897 5700

Fax: 07 3283 1168

ecb@ecb.com.au www.ecb.com.au

29 Snook St
Clontarf QLD 4019
Australia

Po Box 122
Margate QLD 4019
Australia

NB1F28SY

COMMENCED: 11.05.17
REVISED: 00.00.00

FITTING INSTRUCTIONS

FORD F250 SUPER DUTY 1/17 ON 100MM SERIES 2 NUDGE BAR VEHICLE FRONTAL PROTECTION SYSTEM (VFPS) FOR AIR BAG & ADR COMPLIANT VEHICLES

Check installation hardware before commencing.

1. Remove plastic covers from area around tow hooks to access bolts.
2. Remove four 18mm head bumper bar bolts from front of chassis per side **See Figure 1**. Remove two 13mm head bolts from bumper stay per side. Unplug fog lights if required and unplug wiring loom from left hand side chassis rail under radiator. Remove bumper.
3. Remove four 18mm head bolts from tow hook per side.
4. Remove two 18mm head nuts from under run brackets per side.
5. Attach ECB steel mounting brackets (supplied) onto chassis rail under tow hook and front under run bracket using original bolts and two M12 x 1.75 x 40mm bolts, flat washers, spring washers and nuts (supplied) per side, outside holes in chassis rail. Centralise steel mounting bracket to front of vehicle and **tighten all bolts**. **See figures 2 and 3**.
6. Refit bumper in the reverse step of 1 using four M12 x 1.75 x 50mm bolts, flat washers, spring washers and nuts (supplied). Place spacer plates (supplied) between inside of bumper and original equipment chassis bracket to stop bumper twisting out of shape.
7. Attach ECB steel angle bracket (supplied) to outside of tow hook where bumper bar bolts were removed, using four M12 x 1.75 x 40mm bolts, flat washers, spring washers and nuts (supplied). **See figure 4** Align vertical in centre of slot hole and **TIGHTEN FIRM ONLY**. Ensure bumper bar is aligned with vehicle.
8. Check measurement of steel angles so protection bar can mount to outside of steel angle mounts. Adjust steel angle mounts in or out if necessary, ensuring steel angle mounts are kept centred on vehicle.
9. **TIGHTEN STEEL ANGLE MOUNTS.**
10. Install protection bar on outside of steel angle mounts using M10 x 1.5 x 40mm bolts, flat washers, spring washers and nuts (supplied).
11. Align protection bar with vehicle. **See figures 5 and 6. TIGHTEN ALL BOLTS.**

ENSURE NUMBER PLATE IS CLEARLY VISABLE

Note: When fitting/refitting the licence plate to the vehicle, ensure there is no obstruction to licence plate vision in accordance with local authorities. If required relocate licence plate to an alternate location.



**WORLD'S BEST
ALLOY BULLBARS**

East Coast Bullbars (ECB Pty Ltd)

Tel: 07 3897 5700

Fax: 07 3283 1168

ecb@ecb.com.au www.ecb.com.au

29 Snook St
Clontarf QLD 4019
Australia

Po Box 122
Margate QLD 4019
Australia

Further VFPS Notes:

- a) Do not attach VFPS to the vehicle using anchorages not intended for this purpose (e.g. engine mounting bolts).
- b) Do not use this product for any vehicle make or model, other than those specified by the VFPS manufacturer.
- c) Do not remove the plaque or label from the VFPS.
- d) Do not modify the structure of the VFPS in any way.
- e) No accessory or fitment should project forward of the VFPS forward profile.
- f) **ENSURE THESE INSTRUCTIONS ARE LEFT WITH VEHICLE OWNER AND/OR OPERATOR.**

IMPORTANT INFORMATION

Periodically check bolts and nuts for correct tightness, especially if travelling on rough roads

FITTING KIT

1 – Pair steel angle mounts.	12 – M12 nuts
1 – Pair steel chassis mounts	4 – M10 x 1.5 x 40 bolts
2 – Steel 8mm spacer plates (NB1F28SY_C8MS)	8 – M10 flat washers
12 – M12 x 1.75 x 50 bolts	4 – M10 spring washers
24 – M12 flat washers	4 – M10 x 1.5 nuts
12 – M12 spring washers	

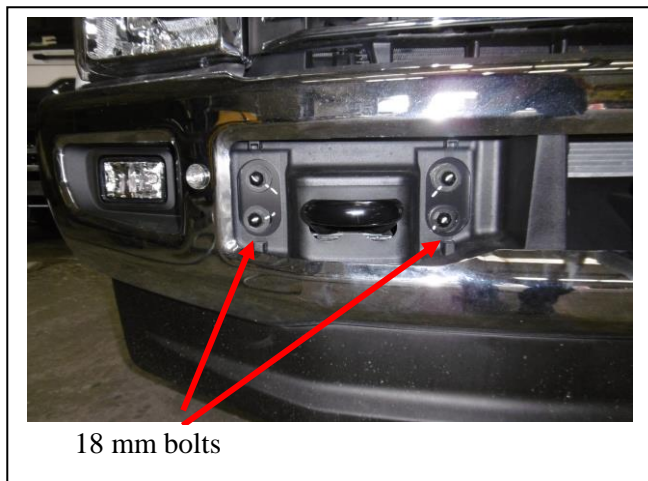

Figure 1



Figure 2



**WORLD'S BEST
ALLOY BULLBARS**

East Coast Bullbars (ECB Pty Ltd)

Tel: 07 3897 5700

Fax: 07 3283 1168

ecb@ecb.com.au www.ecb.com.au

29 Snook St
Clontarf QLD 4019
Australia

Po Box 122
Margate QLD 4019
Australia

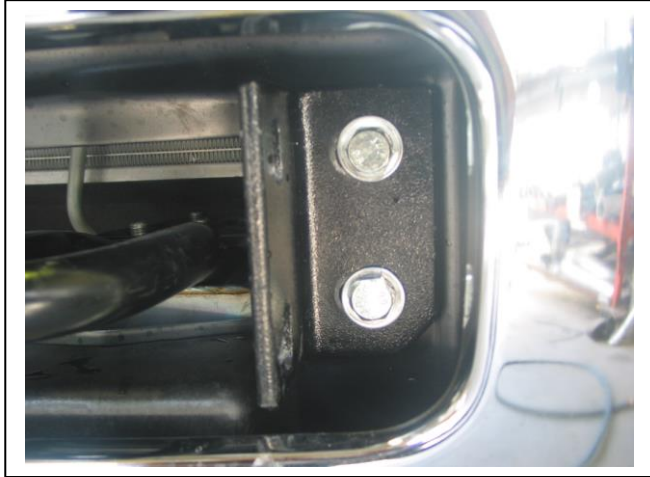

Figure 4 - Steel angle mount fitted



Figure 5 – Front view



Figure 6 - Side view



**WORLD'S BEST
ALLOY BULLBARS**

East Coast Bullbars (ECB Pty Ltd)

Tel: 07 3897 5700

Fax: 07 3283 1168

ecb@ecb.com.au www.ecb.com.au

29 Snook St
Clontarf QLD 4019
Australia

Po Box 122
Margate QLD 4019
Australia

We value your comments

Dear Fitter,

ECB would like to know how you went with the installation of this product. We value your comment and may need to contact you to clarify some details so please complete your contact details clearly.

We would appreciate if you could complete as many of the following details as possible.

Your Name:	Your contact No.
Product Part No.	Product Invoice No.
Product Description:	Make, model, and year of vehicle:
Product Work Order No.	Company you're from/Company product purchased from:

Date of Fitment: ____/____/____

Was the fitting hardware supplied complete?

Yes

No

If no what was not supplied

Did the installation go well?

Yes

No

Please provide comments

Please draw diagrams if you need to.

Post to
Reply Paid 122
PO Box 122
Margate QLD 4019

Fax to
(07) 3283 1168



WORLD'S BEST
ALLOY BULLBARS

East Coast Bullbars (ECB Pty Ltd)

Tel: 07 3897 5700

Fax: 07 3283 1168

ecb@ecb.com.au www.ecb.com.au

29 Snook St
Clontarf QLD 4019
Australia

Po Box 122
Margate QLD 4019
Australia

DESPATCH CHECKLIST NB1F28SY

Work Order #		See other side of this page for photos of all mounts
Finish:		
Transport:		
Due Date:		

OC.....1 – Pair Steel chassis mounting brackets.

OC.....1 – Pair Steel angle mounts

BK.....1 – Steel 8mm spacer plates(NB1F28SY_C8MS)

BK.....1 – Bolt Kit.



Is this product “the best it can be” Yes

If NO fix before continuing

_____/_____
Wrapper's initials / Checker initials

All parts checked and completed by:

Nut and bolts: _____ Date __/__/__

Order control: _____ Date __/__/__

Final wrap check: _____ Date __/__/__



East Coast Bullbars (ECB Pty Ltd)

Tel: 07 3897 5700

Fax: 07 3283 1168

ecb@ecb.com.au www.ecb.com.au

29 Snook St
Clontarf QLD 4019
Australia

Po Box 122
Margate QLD 4019
Australia

WORLD'S BEST
ALLOY BULLBARS

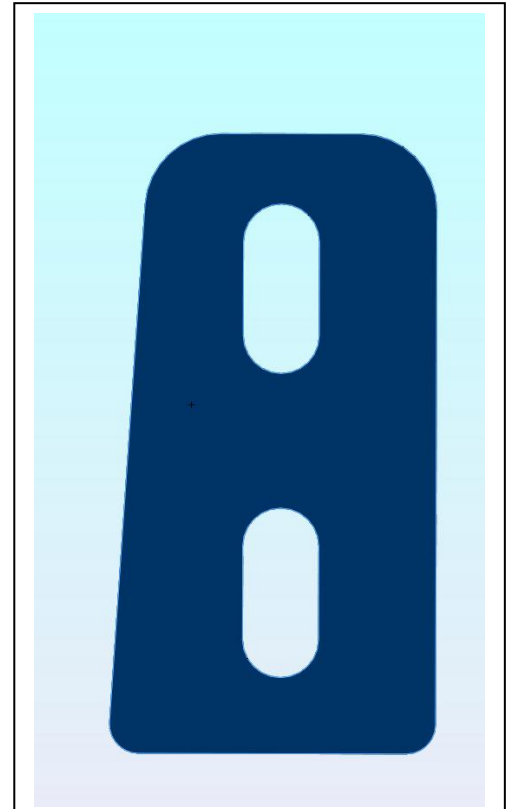
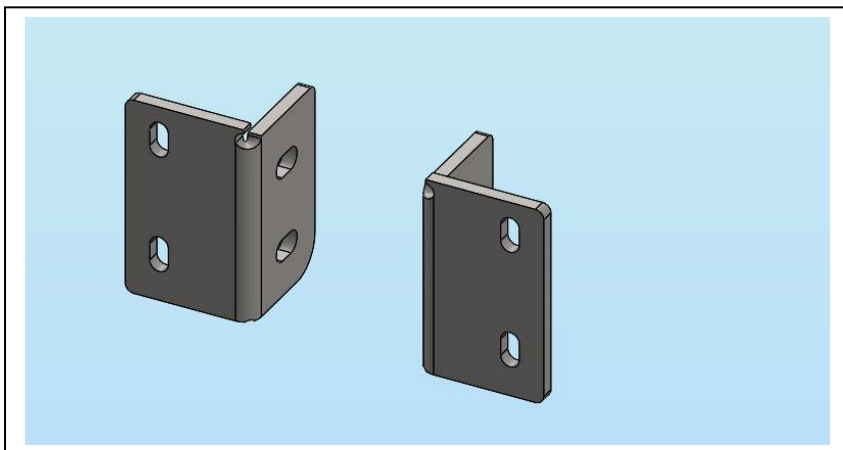
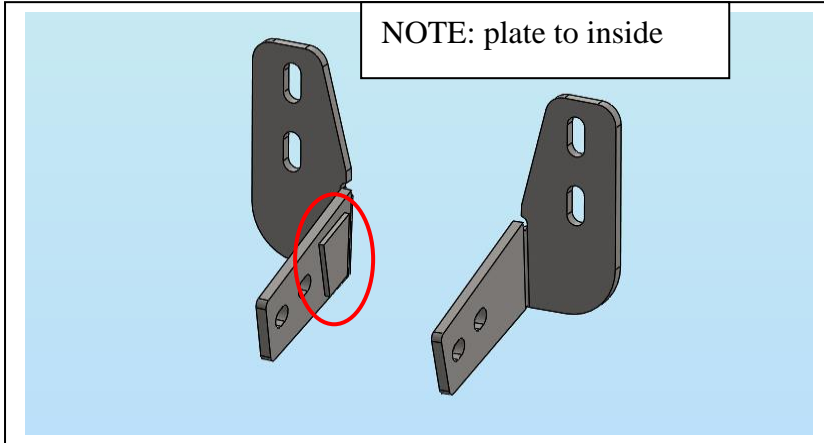

NB1F28SY_C8MS, P/C Black

_____/_____
Wrapper's initials / Checker initials