



**WORLD'S BEST
ALLOY BULLBARS**

East Coast Bullbars (ECB Pty Ltd)

Tel: 07 3897 5700

Fax: 07 3283 1168

ecb@ecb.com.au www.ecb.com.au

29 Snook St
Clontarf QLD 4019

Australia

Po Box 122
Margate QLD 4019
Australia

EAT160SY

REPLACES: 00.00.00

REVISED: 07.01.14

FITTING INSTRUCTIONS

TOYOTA PRADO 10/3on ARC™ PROTECTION BAR WITH FOG LIGHTS VEHICLE FRONTAL PROTECTION SYSTEM (VFPS) FOR AIR BAG & ADR COMPLIANT VEHICLES

Check installation hardware before commencing.

Required extra tools: Jigsaw or similar, to cut bumper.

1. Lift bonnet.
2. Remove grille to radiator cover, 13 push pull plastic clips.
3. Remove four 10mm head bolts and two plastic push pull clips from centre and outer grille, lift outer edge to unclip from headlight. Starting from outside edge of grille, lift up on outer clip, then push down on tab of other clips to unclip. Remove fully from vehicle. **See figures 1 and 2.**
4. Remove two 10mm head bolts (per side) from inner guards and pull rearward to clear bumper side.
5. Disconnect driving lights on passenger's side of vehicle under headlight and headlight washers on driver's side of vehicle.
6. Remove bumper, one 10mm head bolt from bumper wing (per side), four 10mm head bolts from underside of plastic bumper bar, four plastic push pull clips where grille was removed. Slide fingers behind rear edge of plastic bumper to release from clip where screw was removed and gently pull side of bumper away from vehicle to remove. When released from side, pull forward to release from under headlights.
7. Remove centre plastic bash plate, five 10mm head bolts and one plastic push pull clip.
8. Remove Alloy cross member. Three 14mm head nuts (per side)
9. Using a jigsaw or sharp knife, trim plastic air dams to allow fitment of mounts. **See figure 3.**
10. Using 10mm drill, enlarge holes in top and bottom of crash cans. **See figure 4.** In top of crash cans, enlarge holes to 18mm to accept chassis spacers. **Blow all fillings clear and treat all exposed metal with a rust inhibitor.**
11. Fit ECB Steel mounting brackets (supplied) to chassis rail using M8 x 40 bolt, spring washer and flat washer (supplied), M12 x 40 bolt, spring washer and flat washer (supplied) for lower hole and M10 x 40 bolt and washer on 300mm wire, flat washer, spring washer and nut (supplied) to rear hole through rectangular hole further rearward in chassis. **See figure 5. FINGER TIGHTEN ONLY.** At front of chassis, install two steel angle mounts (one top and one bottom of crash can, chassis spacers inserted into crash can assembly on fitment) (supplied). Assemble using two 3/8 x 5 bolts, flat washers, spring washers and nuts (supplied) through steel angles, chassis spacers and chassis, four M10 x 40 bolts, flat washers, spring washers and nuts (supplied) from steel angles to ECB steel mounting brackets.
12. Align mounts to vehicle and **tighten all bolts.** Trim wire from rear bolt and clamp to side of hole to avoid vibration.
13. Check area behind cut is free from hoses and wiring.



**WORLD'S BEST
ALLOY BULLBARS**

East Coast Bullbars (ECB Pty Ltd)

Tel: 07 3897 5700

Fax: 07 3283 1168

ecb@ecb.com.au www.ecb.com.au

29 Snook St
Clontarf QLD 4019

Australia

Po Box 122
Margate QLD 4019

Australia

14. Mask area of plastic bumper to be cut using paper masking tape to avoid damage to painted surface. Using attached templates, mark plastic bumper ready for cut. **See figures 6 and 7** for template placement. Cut bumper using a jigsaw or similar. **CAUTION: Straightness and quality of cut will have an impact on the finish of the final product. Please take care to ensure its correctness.** Fit 3mm clip lock trim to outer cut area of bumper.
15. Refit top section back to vehicle using original bolts as per reverse of step 7.
16. Splice ECB wiring harness into wiring harness behind headlight using cable locks (supplied). Ensure harness is clear of sharp edges and moving parts.
17. Attach wiring to lower leg of channel using zip ties (supplied). **See figures 8 and 9.** Connect ECB Quick Click fog light wiring harness (supplied) into original wiring harness.
18. Fit ECB indicator / park lights into protection bar as per instructions supplied with the LED indicator kit. **NOTE: Ensure park light is to outside. See figure 10.**
19. Attach ECB fog lights to protection bar. Place M6 x 20 bolts, spring washers (supplied) through light mount from inside and attach nut to top. Slide assembly into light mount in Protection bar and centralize light to hole.) **TIGHTEN FIRM ONLY. See figure 11.** Connect to fog light harness.
20. Attach 6mm clip lock trim (supplied) to top of ECB protection bar. **NOTE:** Trim off lower edge on an angle so trim will sit flush with end of protection bar. **See figures 12, 13 and 14.**
21. Fit ECB protection bar to outside of ECB steel mounting brackets using six M12 x 40 bolts, flat washers, spring washers and nuts. **FINGER TIGHTEN ONLY.**
22. Align ECB protection bar to vehicle. **See figure 15 and 16. TIGHTEN ALL BOLTS.**
23. Connect and check indicator / park lights and fog lights
24. Remove M12 bolt from lower mount. Fit ECB outer alloy under body guards to external wing sections of protection bar. Place front of under body guard to top of skirt of protection bar, fit using three M6 x 20 bolts, flat washers and nyloc nuts (supplied) (per side). **See figure 17.** Push inner guard up into guard and trim inner guard level with bottom of under body guard. Using under body guard as a guide, drill holes on lower lip through inner guard with a 6mm drill. Attach using two M6 x 20 bolts, flat washers and nyloc nuts (supplied). **TIGHTEN ALL BOLTS.**
25. Fit centre under body guard to top of protection bar skirt using four M6 x 20 bolts, flat washers and nyloc nuts (supplied). ECB under body guard bolts to original steel bash plate using original bolts to outside. **TIGHTEN ALL BOLTS.**

ENSURE NUMBER PLATE IS CLEARLY VISABLE

Note: When fitting/refitting the licence plate to the vehicle, ensure there is no obstruction to licence plate vision in accordance with local authorities. If required relocate licence plate to an alternate location.

Further VFPS Notes:

- a) Do not attach VFPS to the vehicle using anchorages not intended for this purpose (e.g. engine mounting bolts).
- b) Do not use this product for any vehicle make or model, other than those specified by the VFPS manufacturer.
- c) Do not remove the plaque or label from the VFPS.
- d) Do not modify the structure of the VFPS in any way.
- e) No accessory or fitment should project forward of the VFPS forward profile.



**WORLD'S BEST
ALLOY BULLBARS**

East Coast Bullbars (ECB Pty Ltd)

Tel: 07 3897 5700

Fax: 07 3283 1168

ecb@ecb.com.au www.ecb.com.au

29 Snook St
Clontarf QLD 4019
Australia

Po Box 122
Margate QLD 4019
Australia

f) **ENSURE THESE INSTRUCTIONS ARE LEFT WITH VEHICLE OWNER AND/OR OPERATOR.**

IMPORTANT INFORMATION

Periodically check bolts and nuts for correct tightness, especially if travelling on rough roads

FITTING KIT

| | |
|---|---|
| 1 – Pair steel mounting brackets | 2 – M8 flat washers |
| 4 – Steel angle brackets | 4 – 3/8 x 5 bolts |
| 4 – 81mm long 10 Nb Steel spacer tubes | 4 – 3/8 nuts |
| 1 – Pair side under body skirts | 2 – M6 nuts |
| 1 – Centre under body skirt | 18 – M6 x 20 bolts |
| 8 – M12 x 1.25 x 40 bolts(2 bolts to be left out for packaging) | 32 – M6 flat washers |
| 14 – M12 flat washers(4 washers to be left out for packaging) | 2 – M6 spring washers |
| 8 – M12 spring washers | 16 – M6 nyloc nuts |
| 6 – M12 x 1.25 nuts (2 nuts to be left out for packaging) | 1 – ECB LED Indicator / Park light kit |
| 8 – M10 x 1.25 x 40 bolts | 6 – cable locks |
| 2 – M10 x 1.25 x 40 bolt and washer on 300mm wire | 1 – Pair ECB fog lights (35 watt) |
| 26 – M10 flat washers | 1 – Quick Click Fog Harness (IC10D40S1004ECBH) |
| 14 – M10 spring washers | 4 – Fog light surrounds |
| 10 – M10 x 1.25 nuts | 1 – 2600mm length 6mm clip lock trim |
| 2 – M8 x 1.25 x 40 bolts | 2 – 500mm length 3mm clip lock trim |
| 2 – M8 spring washers | 15 – 150mm zip ties |



Figure 1: Grille outer lower bumper clip

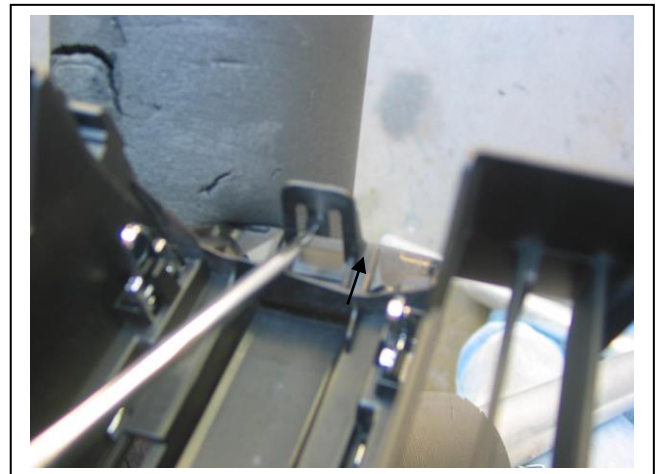

Figure 2: Grille inner lower bumper clip



East Coast Bullbars (ECB Pty Ltd)

Tel: 07 3897 5700

Fax: 07 3283 1168

ecb@ecb.com.au www.ecb.com.au

WORLD'S BEST
ALLOY BULLBARS

29 Snook St
Clontarf QLD 4019
Australia

Po Box 122
Margate QLD 4019
Australia

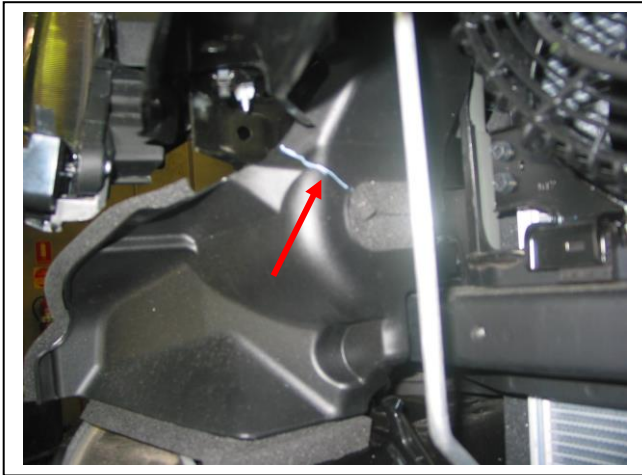

Figure 3: Trim point on drivers side air dam.

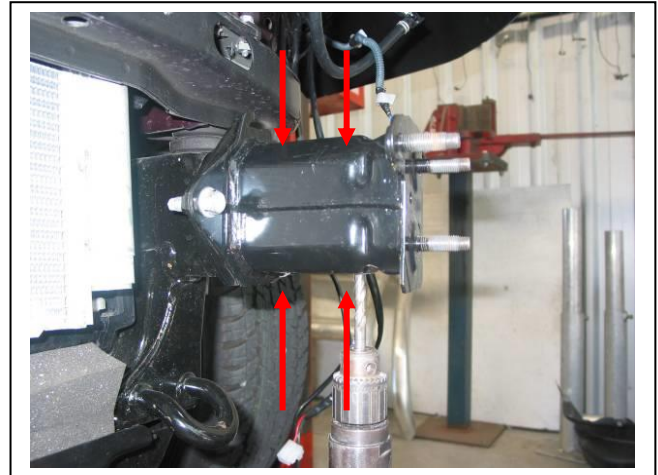

Figure 4: Drill holes to 10mm (3/8). Drill or die grind top to 18mm.

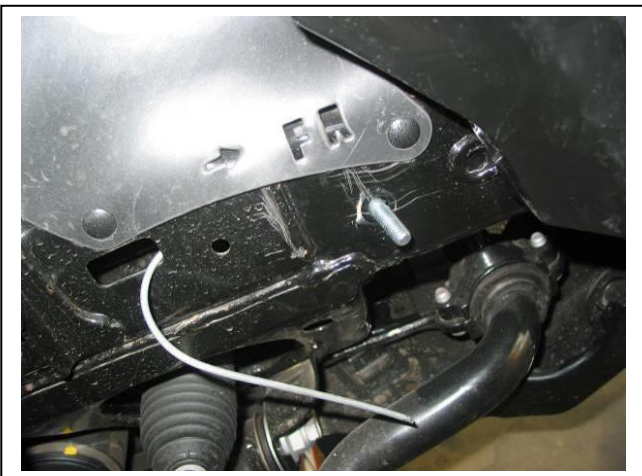

Figure 5: Rear bolt on wire fitted before mount is assembled for photo



Figure 6: Cut line across front of vehicle.



Figure 7: Cut line across front of vehicle.



Figure 8: Wiring secured into bar. Parking sensor bar shown.



East Coast Bullbars (ECB Pty Ltd)

Tel: 07 3897 5700

Fax: 07 3283 1168

ecb@ecb.com.au www.ecb.com.au

WORLD'S BEST
ALLOY BULLBARS

29 Snook St
Clontarf QLD 4019
Australia

Po Box 122
Margate QLD 4019
Australia



Figure 9: Wiring secured into bar. Parking sensor bar shown. NOTE wiring direction secured to

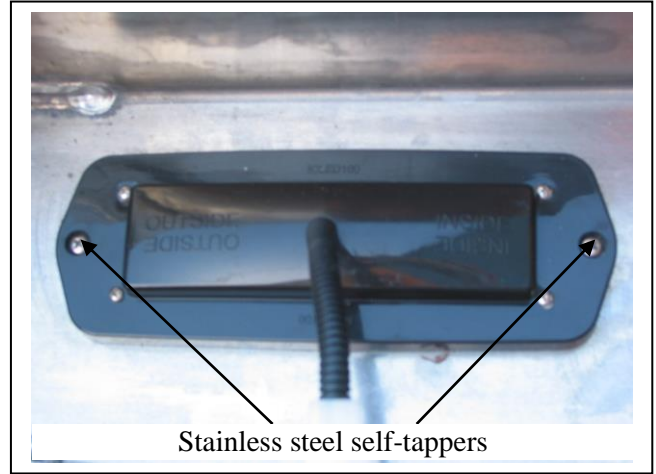
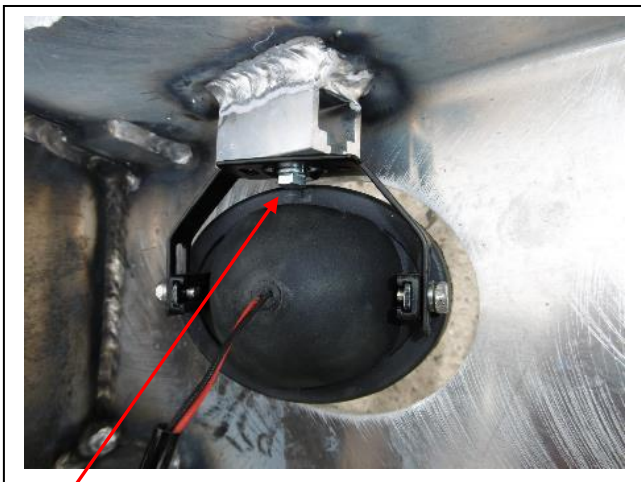

Figure 10

Stainless steel self-tappers



M6 Bolt

Figure 11

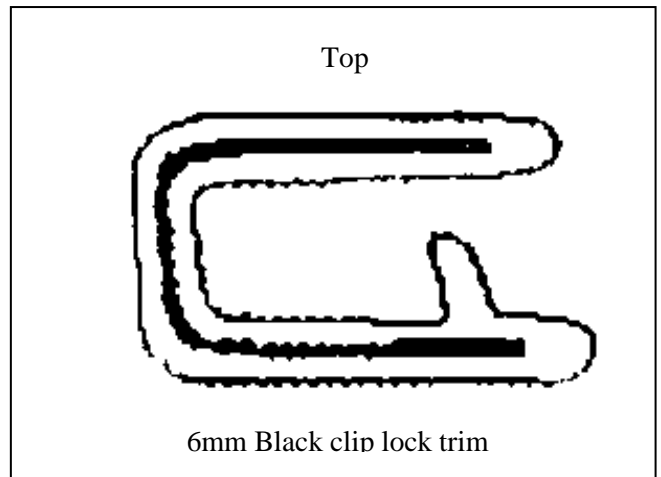

Top

6mm Black clip lock trim

Figure 12

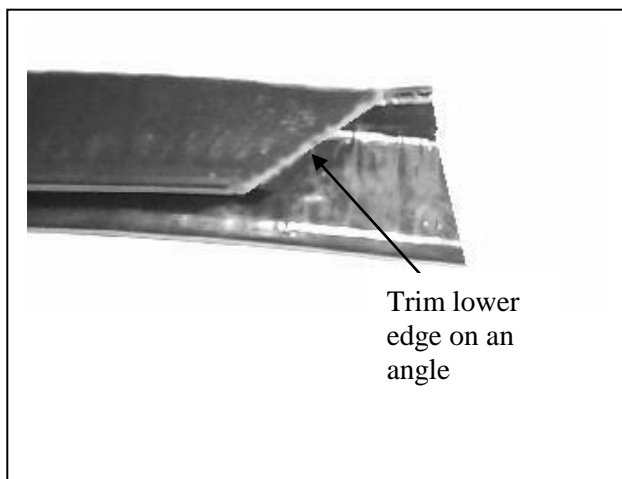

Trim lower edge on an angle

Figure 13

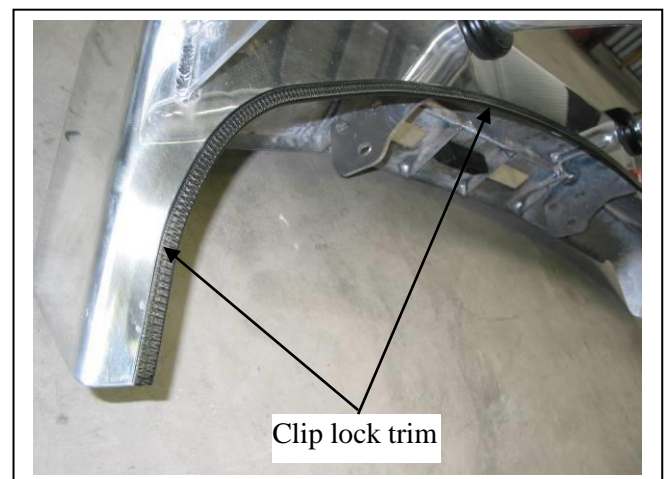

Clip lock trim

Figure 14



East Coast Bullbars (ECB Pty Ltd)

Tel: 07 3897 5700

Fax: 07 3283 1168

ecb@ecb.com.au www.ecb.com.au

WORLD'S BEST
ALLOY BULLBARS

29 Snook St
Clontarf QLD 4019
Australia

Po Box 122
Margate QLD 4019
Australia



Figure 15: Front view



Figure 16: Side view



Figure 17: Passengers side under body guard

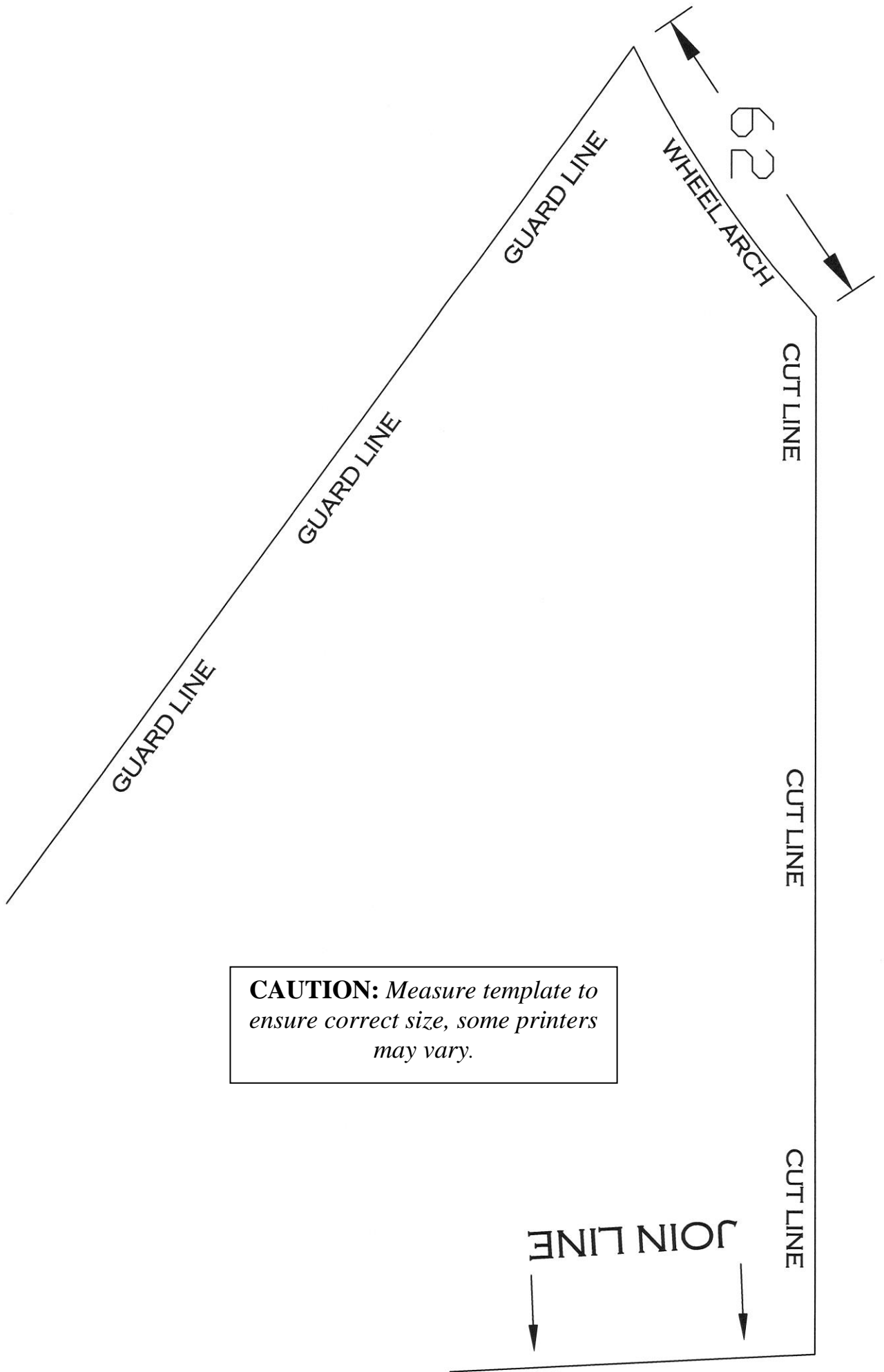

CAUTION: *Measure template to ensure correct size, some printers may vary.*



**WORLD'S BEST
ALLOY BULLBARS**

East Coast Bullbars (ECB Pty Ltd)

Tel: 07 3897 5700

Fax: 07 3283 1168

ecb@ecb.com.au www.ecb.com.au

29 Snook St
Clontarf QLD 4019
Australia

Po Box 122
Margate QLD 4019
Australia

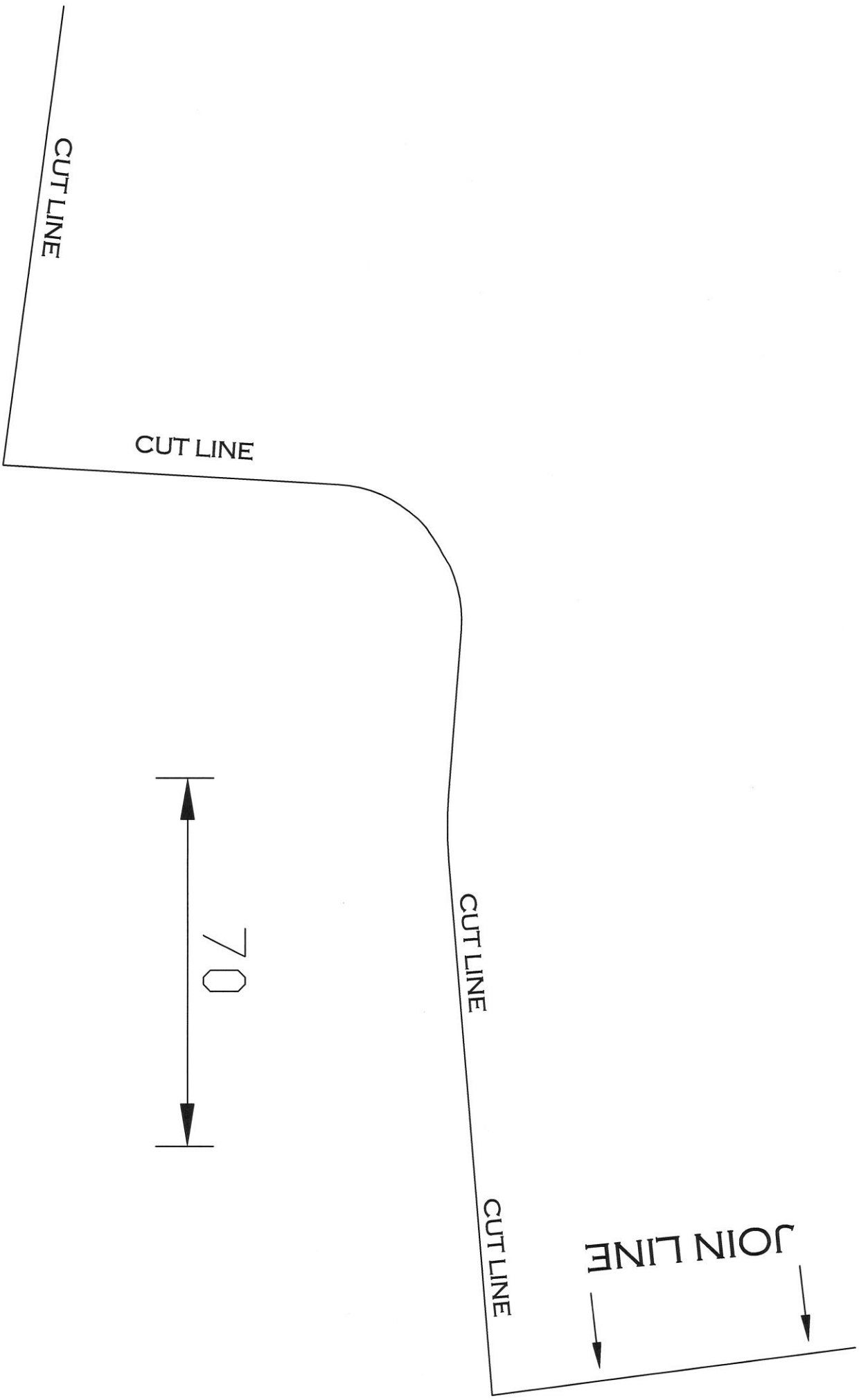

CUT LINE

CUT LINE

CUT LINE

CUT LINE

JOIN LINE

70



**WORLD'S BEST
ALLOY BULLBARS**

East Coast Bullbars (ECB Pty Ltd)

Tel: 07 3897 5700

Fax: 07 3283 1168

ecb@ecb.com.au www.ecb.com.au

29 Snook St
Clontarf QLD 4019
Australia

Po Box 122
Margate QLD 4019
Australia



**WORLD'S BEST
ALLOY BULLBARS**

East Coast Bullbars (ECB Pty Ltd)

Tel: 07 3897 5700

Fax: 07 3283 1168

ecb@ecb.com.au www.ecb.com.au

29 Snook St
Clontarf QLD 4019
Australia

Po Box 122
Margate QLD 4019
Australia

We value your comments

Dear Fitter,

ECB would like to know how you went with the installation of this product. We value your comment and may need to contact you to clarify some details so please complete your contact details clearly.

We would appreciate if you could complete as many of the following details as possible.

| | |
|-------------------------------|--|
| Your Name: | Your contact No. |
| Product Part No. | Product Invoice No. |
| Product Description: | Make, model, and year of vehicle: |
| Product Work Order No. | Company your from/Company product purchased from: |

Date of Fitment: ____/____/____

| | | |
|---|--------------------------|--------------------------|
| | Yes | No |
| Was the fitting hardware supplied complete? | <input type="checkbox"/> | <input type="checkbox"/> |

If no what was not supplied

| | | |
|-------------------------------|--------------------------|--------------------------|
| | Yes | No |
| Did the installation go well? | <input type="checkbox"/> | <input type="checkbox"/> |

Please provide comments

Please draw diagrams if you need to.

Post to
Reply Paid 122
PO Box 122
Margate QLD 4019

Fax to
(07) 3283 1168



**WORLD'S BEST
ALLOY BULLBARS**

East Coast Bullbars (ECB Pty Ltd)

Tel: 07 3897 5700

Fax: 07 3283 1168

ecb@ecb.com.au www.ecb.com.au

29 Snook St
Clontarf QLD 4019
Australia

Po Box 122
Margate QLD 4019
Australia



WORLD'S BEST
ALLOY BULLBARS

East Coast Bullbars (ECB Pty Ltd)

Tel: 07 3897 5700

Fax: 07 3283 1168

ecb@ecb.com.au www.ecb.com.au

29 Snook St
Clontarf QLD 4019

Australia

Po Box 122
Margate QLD 4019

Australia

DESPATCH CHECKLIST EAT160SY

| | | |
|--------------|--|---|
| Work Order # | | See other side of this page for photos of all mounts |
| Finish: | | |
| Transport: | | |
| Due Date: | | |

- OC.....1 – Pair steel mounting brackets
- OC.....4 – Steel angle brackets
- BK.....1 – Bolt Kit
- BK.....1 – ECB LED indicator / park light kit
- BK.....1 – Fog light kit (35 watt)
- BK.....1 - Quick Click Fog Harnesses (IC10D40S1004ECBH)
- BK.....4 – Fog light surrounds
- BK.....1 – 2600mm length 6mm clip lock
- BK.....2 – 500mm lengths 3mm clip lock
- OC.....1 – Centre under body guard (powder coated black ripple)
- OC.....1 – Pair side under body guards (powder coated black ripple)
- OC.....2 – ECB Overrides – **Fitted to bar**
- OC.....4 – 6mm air vents – **Fitted to bar**



Is this product “the best it can be” Yes _____/_____
Wrapper’s initials / Checker initials

If **NO** fix before continuing

All parts checked and completed by:

Nut and bolts: _____ Date __/__/__

Order control: _____ Date __/__/__

Final wrap check: _____ Date __/__/__



East Coast Bullbars (ECB Pty Ltd)

Tel: 07 3897 5700

Fax: 07 3283 1168

ecb@ecb.com.au www.ecb.com.au

29 Snook St
Clontarf QLD 4019
Australia

Po Box 122
Margate QLD 4019
Australia

WORLD'S BEST
ALLOY BULLBARS

