



**WORLD'S BEST
ALLOY BULLBARS**

East Coast Bullbars (ECB Pty Ltd)

Tel: 07 3897 5700

Fax: 07 3283 1168

ecb@ecb.com.au www.ecb.com.au

29 Snook St
Clontarf QLD 4019
Australia

Po Box 122
Margate QLD 4019
Australia

BN54SY

REPLACES: 18.02.10
REVISED: 29.06.10

FITTING INSTRUCTIONS

NISSAN NAVARA 02- 4X4 BIG TUBE™ BULLBAR VEHICLE FRONTAL PROTECTION SYSTEM (VFPS) FOR AIR BAG & ADR COMPLIANT VEHICLES

Check installation hardware before commencing.

1. Remove bumper. One bumper stay (each side), one 12mm nut (each side) at side returns and two 17mm head bolts (each side) at front side of chassis.
2. Splice ECB indicator / park light splice wiring (supplied – connected to indicator / park lights with plug) into original park light / indicator wiring. Use cable locks (supplied).
3. Position cross brace between protection bar steel chassis mounting brackets. Attach to centre 3 slots using 3/8 x 1 1/4 bolts. Finger tighten only. **See figure 1.**
4. Position the steel mounting brackets on chassis and insert the M10 x 40 x 1.25 bolts (supplied). **DO NOT TIGHTEN. See figure 2.**
5. Fit ECB LED indicator / park lights (supplied) into protection bar as per instructions supplied with the LED indicator kit. **NOTE: Ensure park light is to outside. See figure 3.**
6. Attach the protection bar to the inside of the steel mounting brackets. Use the 1/2 x 1 1/2 bolts/nuts (supplied). **DO NOT TIGHTEN.**
7. Remove rubber damper mounts from bumper side returns. Fit back over original bumper mount stud on vehicle with steel cover at bottom (same as removed from bumper). Attach alloy angle (supplied) to bumper mount stud (use original nut) and to bracket welded to protection bar, use 3/8 x 1 1/4 bolt/nut/washers (supplied). **FINGER TIGHTEN ONLY. See diagram 1 and figure 4**
8. Align protection bar with vehicle ensuring steel mounting brackets are positioned correctly at lower tie down bracket area. **See figure 5. TIGHTEN** steel mounting brackets in position and cross brace and then protection bar. **TIGHTEN RUBBER DAMPER MOUNTS AND ALLOY ANGLES.**
9. **NOTE:** Leave approximately 10mm clearance between protection bar and guards when viewed from the side. This will allow for body movement in rough terrain. **See figure 6.**
10. Drill 1/2" holes through the chassis tie down points using the mounts as a guide and insert the 1/2 x 1 1/2 bolts/nuts (supplied). **TIGHTEN ALL BOLTS. See figure 7. Treat bare metal with rust inhibitor or similar.**
11. Connect ECB indicator / park lights. **CHECK OPERATION.**

ENSURE NUMBER PLATE IS CLEARLY VISABLE

Note: When fitting/refitting the licence plate to the vehicle, ensure there is no obstruction to licence plate vision in accordance with local authorities. If required relocate licence plate to an alternate location.



East Coast Bullbars (ECB Pty Ltd)

Tel: 07 3897 5700

Fax: 07 3283 1168

ecb@ecb.com.au www.ecb.com.au

29 Snook St
Clontarf QLD 4019
Australia

Po Box 122
Margate QLD 4019
Australia

WORLD'S BEST
ALLOY BULLBARS

Further VFPS Notes:

- a) Do not attach VFPS to the vehicle using anchorages not intended for this purpose (e.g. engine mounting bolts).
- b) Do not use this product for any vehicle make or model, other than those specified by the VFPS manufacturer.
- c) Do not remove the plaque or label from the VFPS.
- d) Do not modify the structure of the VFPS in any way.
- e) No accessory or fitment should project forward of the VFPS forward profile.
- f) **ENSURE THESE INSTRUCTIONS ARE LEFT WITH VEHICLE OWNER AND/OR OPERATOR.**

FITTING KIT

2 – Steel mounting brackets.	8 – 3/8 nuts.
1 – Steel cross brace.	20 – 3/8 flat washers.
2 – Alloy angles.	12 – 3/8 spring washers.
10 – 1/2 x 1 1/2 bolt/nuts.	1 – ECB LED Indicator / Park light kit
20 – 1/2 flat washers.	6 – Cable locks.
10 – 1/2 spring washers.	
4 – M10 x 40 x 1.25 bolts.	
8 – 3/8 x 1 1/4 bolts.	



Figure 1

M10 x 40 x 1.25 bolts

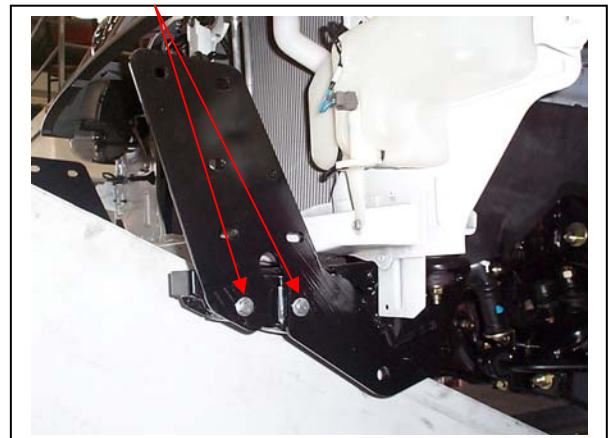

Figure 2



East Coast Bullbars (ECB Pty Ltd)

Tel: 07 3897 5700

Fax: 07 3283 1168

ecb@ecb.com.au www.ecb.com.au

29 Snook St
Clontarf QLD 4019
Australia

Po Box 122
Margate QLD 4019
Australia

WORLD'S BEST
ALLOY BULLBARS



Figure 3
Stainless steel self-tappers

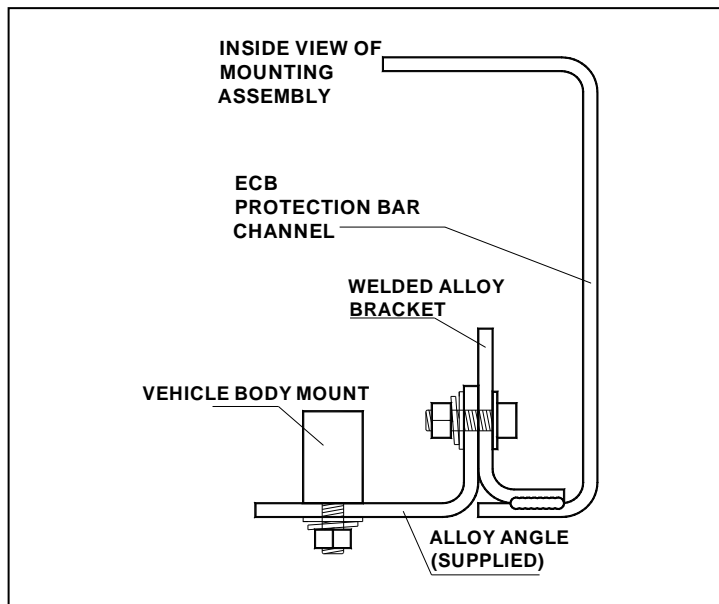

Diagram 1



East Coast Bullbars (ECB Pty Ltd)

Tel: 07 3897 5700

Fax: 07 3283 1168

ecb@ecb.com.au www.ecb.com.au

29 Snook St
Clontarf QLD 4019
Australia

Po Box 122
Margate QLD 4019
Australia

WORLD'S BEST
ALLOY BULLBARS

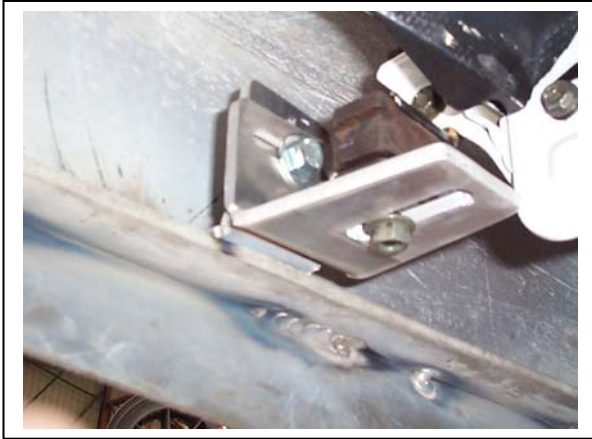

Figure 4



Figure 5



Figure 6

Approximately
10mm clearance



Figure 7



**WORLD'S BEST
ALLOY BULLBARS**

East Coast Bullbars (ECB Pty Ltd)

Tel: 07 3897 5700

Fax: 07 3283 1168

ecb@ecb.com.au www.ecb.com.au

29 Snook St
Clontarf QLD 4019
Australia

Po Box 122
Margate QLD 4019
Australia

We value your comments

Dear Fitter,

ECB would like to know how you went with the installation of this product. We value your comment and may need to contact you to clarify some details so please complete your contact details clearly.

We would appreciate if you could complete as many of the following details as possible.

Your Name:	Your contact No.
Product Part No.	Product Invoice No.
Product Description:	Make, model, and year of vehicle:
Product Work Order No.	Company your from/Company product purchased from:

Date of fitment: ____/____/____

Was the fitting hardware supplied complete?

Yes

No

If no what was not supplied

Did the installation go well?

Yes

No

Please provide comments

Please draw diagrams if you need to.

Post to

Reply Paid 122

PO Box 122

Margate QLD 4019

Fax to

(07) 3283 1168



**WORLD'S BEST
ALLOY BULLBARS**

East Coast Bullbars (ECB Pty Ltd)

Tel: 07 3897 5700

Fax: 07 3283 1168

ecb@ecb.com.au www.ecb.com.au

29 Snook St
Clontarf QLD 4019
Australia

Po Box 122
Margate QLD 4019
Australia



WORLD'S BEST
ALLOY BULLBARS

East Coast Bullbars (ECB Pty Ltd)

Tel: 07 3897 5700

Fax: 07 3283 1168

ecb@ecb.com.au www.ecb.com.au

29 Snook St
Clontarf QLD 4019
Australia

Po Box 122
Margate QLD 4019
Australia

DESPATCH CHECKLIST BN54SY

Work Order #	
Finish:	
Transport:	
Due Date:	

- 2 – Steel mounting brackets.
- 1 – Steel cross brace.
- 2 – Alloy angles.
- 1 – Bolt Kit.
- 1 – ECB LED Indicator / Park light kit.
- 2 – ECB overrides – **fitted to bar.**
- 3 – 3mm Air Scoops – **fitted to bar.**
- 2 – 6mm Air Scoops – **fitted to bar.**

**See other side of
this page for
photos of all
mounts**



Is this product “the best it can be” Yes _____/_____

Wrapper's initials / Checker initials

If **NO** fix before continuing

All parts checked and completed by:

Nut and bolts: _____ Date __/__/__

Order control: _____ Date __/__/__

Final wrap check: _____ Date __/__/__



**WORLD'S BEST
ALLOY BULLBARS**

East Coast Bullbars (ECB Pty Ltd)

Tel: 07 3897 5700

Fax: 07 3283 1168

ecb@ecb.com.au www.ecb.com.au

29 Snook St
Clontarf QLD 4019
Australia

Po Box 122
Margate QLD 4019
Australia

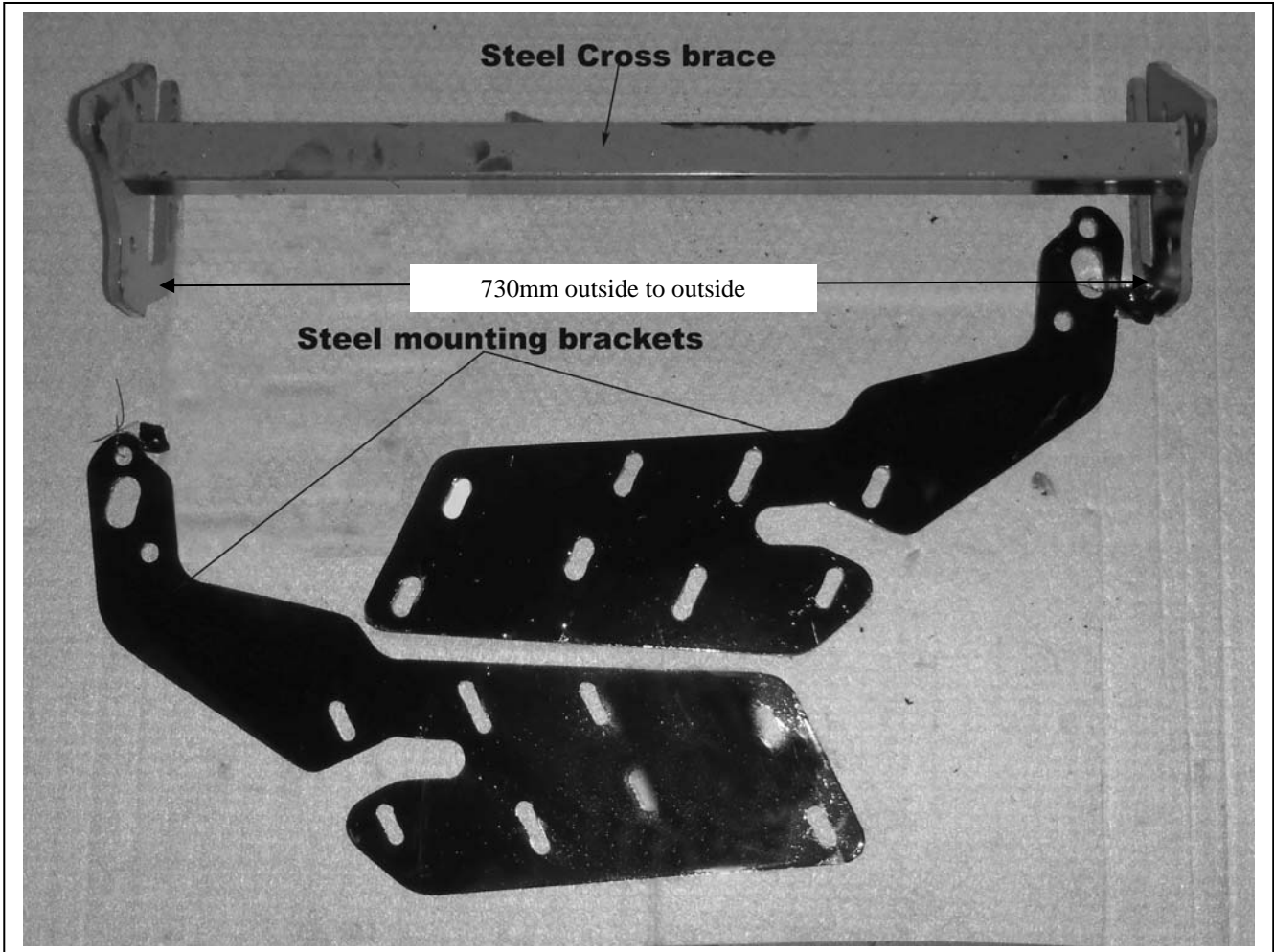

NOTE: The steel cross brace is 730mm Outside to Outside, and is shorter than a BN55SY