



**Safer
Lighter
Stronger**

PN:EDF185SY



Fitting Guide & Owners Manual

Ford Ranger

5 - 2022on

3 HOOP BAR
VEHICLE FRONTAL PROTECTION SYSTEM (VFPS)
FOR AIR BAG & ADR COMPLIANT VEHICLES

Index

Pages 3-5

ECB's Benefits
Product Care

Pages 6-7

Stage 1 - Vehicle Testing and Preparation
Stage 2- Radiator cover
Stage 3 - Grille removal
Stage 4 - Underside bumper
Stage 5 - Inner guard
Stage 6 - Bumper/ guard join

Pages 8-9

Stage 7- Number plate cover
Stage 8 - Inner Grille
Stage 9 - Camera
Stage 10 - Bumper removal
Stage 11 - Sonar cover
Stage 12 - Bumper support

Pages 10-11

Stage 13- Sonar
Stage 14- Lower cooler
Stage 15 - Bumper support
Stage 16 - Horns
Stage 17 - Radiator shroud
Stage 18 - Tow hook

Pages 12-13

Stage 19 to 20 Recovery hooks
Stage 21 to 22 - Mount/ winch fitment
Stage 23 to 24- Parking sensors

Pages 14-15

Stage 25 - Fog lights Sonar mount
Stage 26 - Camera
Stage 27 - Sonar
Stage 28 - Clip lock
Stage 29 - Trim bumper
Stage 30 - Refit bumper

Pages 16-17

Stage 31 - Protection Bar Fittment
Stage 32 - Connect camera/lights/sonar
Stage 33 - Underbody guards
Stage 34 - Final checks
Fitting kit

Pages 18-19

Installation kit
Finished product

Pages 20-21

Notes
Warranty registration

The Features of ECB

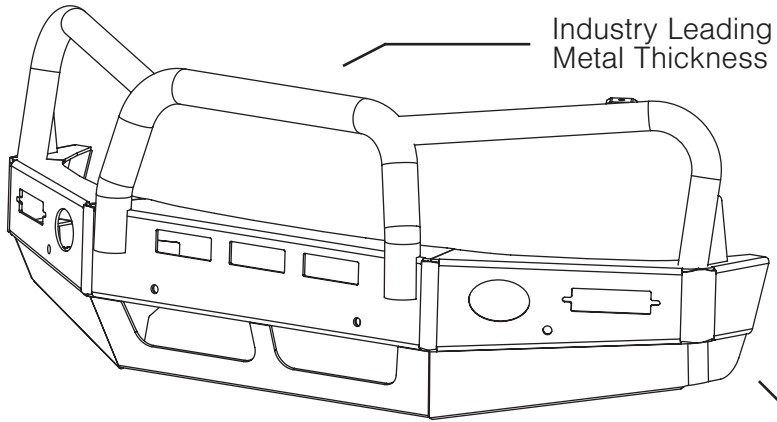

Industry Leading
Metal Thickness

6mm Thick
Hi-Tensile Alloy

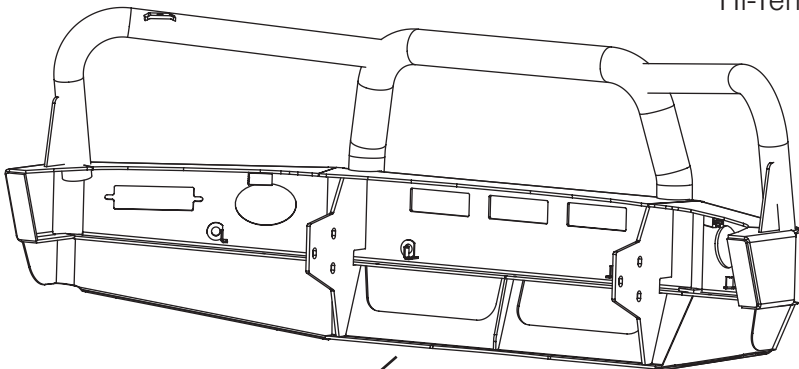

Unmatched
Strength

Fully Welded
Construction

ECB's Benefits

Built to Perform - Not to a Price

ECB are proud to claim that their channels are not jigsaw puzzles that are bolted together, or even multiple sections welded together. Where any welding is required, it is done to the highest standards by qualified welders, not machines.

Anti-Corrosive Nature of Alloy

The composition of ECB's alloy has a very high resistance to corrosion. Rust not only looks unappealing but greatly reduces the strength of the metal. Rust can and will weaken the structural integrity of a steel bullbar effectively rendering it useless over time.

Australian Made

Established in 1971, we utilise decades of experience designing, engineering and building products in Australia to suit Australian conditions. We can ensure the best quality controls and help support the local economy and employ over 90 proud Australians.

Weight Saving Benefits

An ECB alloy bullbar is typically half the weight of a steel bullbar. Unnecessary suspension upgrades are not required. The reduced weight also contributes to increased fuel economy and less wear and tear on tyres, suspension and braking components.

Welds That Work

ECB uses only the strongest welds and welding techniques to ensure every product is as structurally sound as possible. MIG (Metal Inert Gas) welding techniques are employed ensuring the welds are as thick as the thickest section of alloy's being joined together.

Lifetime Warranty

ECB provide a lifetime warranty and consumer guarantee on all of our manufactured products. This guarantee highlights the confidence in our ability and provides complete peace of mind for your purchase for the lifetime you own your vehicle.

Product Care

Polished Products

Being a premium mirror polished finish, regular maintenance will be required to keep that iconic ECB shine. We recommend using our own brand of Aluminium Polish. This formula has been tried and tested and in our opinion is the world's best standard.

Directions: Apply a small quantity of Aluminium Polish to a clean soft cloth and rub the metal surface. The longer the rubbing the brighter the surface becomes. Wipe off Aluminium Polish with clean soft cloth. Also suitable for motorised buffing machines.

Note: There are more specific details on the polish bottle. Please read before use.

Powdercoated Products

Our powdercoated finishes are very low maintenance. Infact there is actually very little you will ever need to do for this product. Just clean it as you would your car and it will stay looking good as new.

ECB Aluminium Polish

When you're looking for that showroom finish look for your polished automotive products, you can depend on the no compromise quality of East Coast Bullbars Aluminium Polish. This specifically designed product is the best polish available and we guarantee that this \$#!+ works. Within our decades of manufacturing polished alloy products we have trialed a large range of different polishes on the market and believe without a doubt that nothing beats the finish quality of East Coast Bullbars Aluminium Polish.

East Coast Bullbars Aluminium Polish is excellent for use by hand and is ideal for polished bullbars, nudge bar and stainless steel products. This polish will clean, polish and protect your product from the elements whilst bringing your products back to that showroom finish look.



EDF185SY

Stage 1

- Test drive vehicle to ensure all driver assists are correctly working and to gauge effectiveness. Park on a flat level surface.
- Apply parking brake and lift bonnet.
- Unwrap ECB Protection bar and disconnect mounts. Discard bolts.
- Ensure these instructions are left with the vehicle owner and/or operator.



DISCONNECT BATTERY.

Stage 2

- Remove radiator cover, 13 plastic scrivenets, remove plastic cover



Stage 3

- On rear of grille beside headlights remove one (1) 8mm head bolts (per side).
- Disconnect parking sensor/ sonar harness.
- Remove main plug from top of radiator cover and feed harness down inside behind grille. For connection once protection bar is fitted.

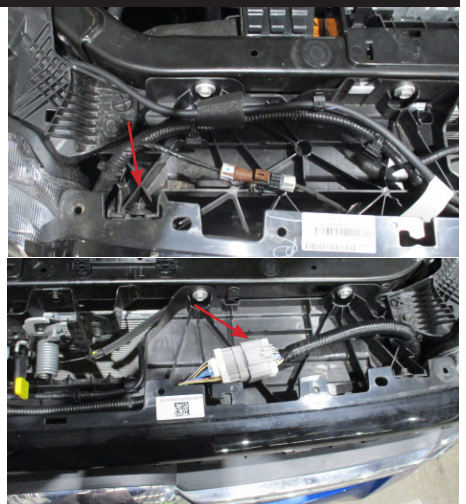

Ford Ranger 5-2022 on

Stage 4

- Underside of bumper remove one (1) T25 torx screw (per side) and 8mm head bolt, second bolt in from end (per side).



Stage 5

- From Inner wheel arch remove four (4) push pull clips from inner flare (per side).
- On Inner guard cover, remove three (3) plastic scrivets. Remove cover to access inner bumper cover/ guard join.

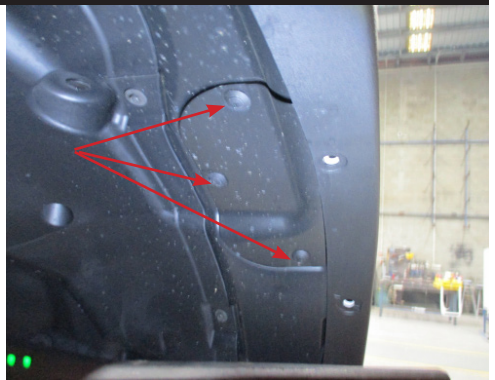

Stage 6

- Inside of bumper/ guard join, remove three (3) 10mm head bolts (per side).



EDF185SY

Stage 7

- Remove number plate cover two (2) 8mm head bolts



Stage 8

- Pull centre grille forward and remove from bumper, three (3) push pull clips and two (2) 10mm head bolts.

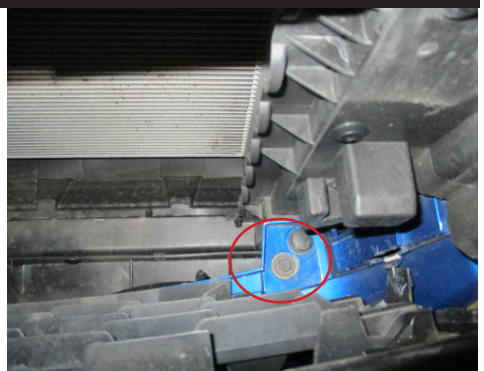

Stage 9

- Disconnect camera cable and camera washer hose, from rear of camera housing.

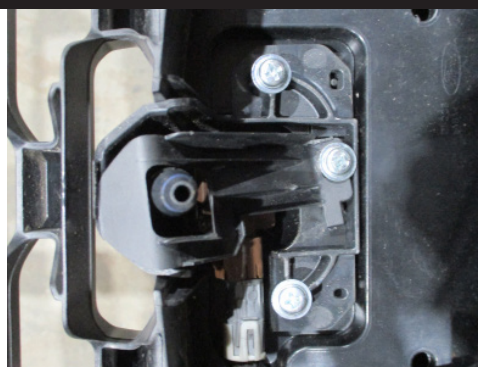

Ford Ranger 5-2022 on

Stage 10

- Carefully pull flares away from vehicle. From inside inner guard squeeze retaining clip and gently pull down on bumper to remove.
- Remove bumper.



Stage 11

- Remove sonar cover two (2) push pull clips side of housing.
- Disconnect harness from sonar, release harness from front bumper support.
- Trim cover ready for refitment.



Stage 12

- Remove foam from bumper infill two (2) push pull clips.
- From front of chassis rail remove six (6) 13mm head bolts and remove bumper support.

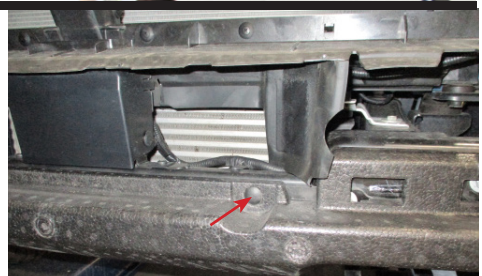

EA F185SY

Stage 13

- Remove sonar from rail three (3) T30 Torx screws. One per side and one at rear.
- Refit cover to avoid any damage to sonar.

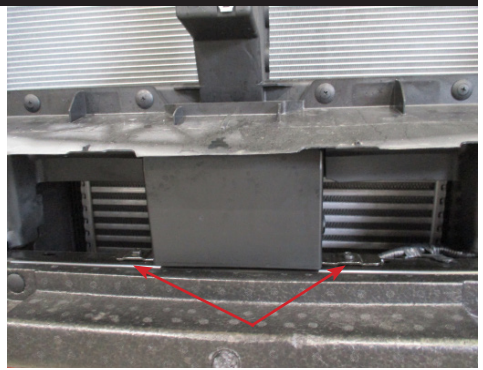

Stage 14

- Remove lower intercooler shroud, four (4) 8mm head bolts.



Stage 15

- Remove bumper supports, three (3) 8mm head bolts and one (1) push pull clip (per side).



Ford Ranger 5-2022 on

Stage 16

- On drivers side, remove horns and turn up side down.
- Using original 8mm head bolt place horns where bumper support was removed.



Stage 17

- Trim radiator shroud to suit steel mount.

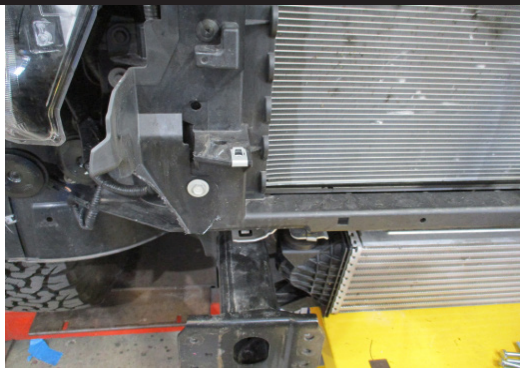

Stage 18

- Loosen two (2) rear bolts on underbelly guard and remove front two (2) bolts, slide guard forward and remove.
- From underside of chassis rail remove tow hook/ intercooler supports, two (2) 15mm head bolts (per side). Retain bolts for refitment.
- Support intercooler on removal of tow hook brackets.

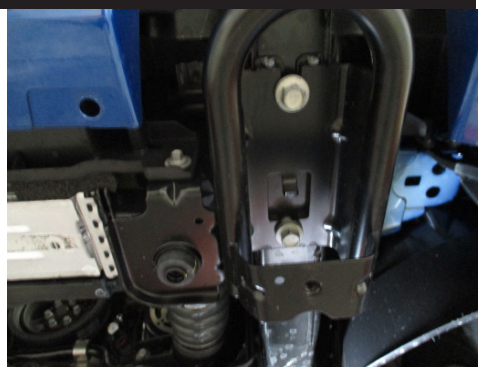

EDF185SY

Stage 19

- Place steel winch frame onto vehicle. Bolts are installed with Rated recovery hooks.
- Fit Recovery hooks to underside of chassis rail with 8mm spacer plates between bottom of chassis rail and recovery hook
- Replace 15mm head bolt previously removed from tow hook. Finger tighten only.
- On rear hole place round 3mm thrust washer on bolt before installing.



Stage 20

- Recovery hooks slide in between steel mount and end of chassis rail, and pick up intercooler. Ensure rubber supports on intercooler sit into holes on recovery hook and top of intercooler mount on vehicle.
- Install mount to front of chassis rail. Place M12 x 120mm bolt and M12 flat washer through outer side of chassis rail to hold mount and recovery hook in place.

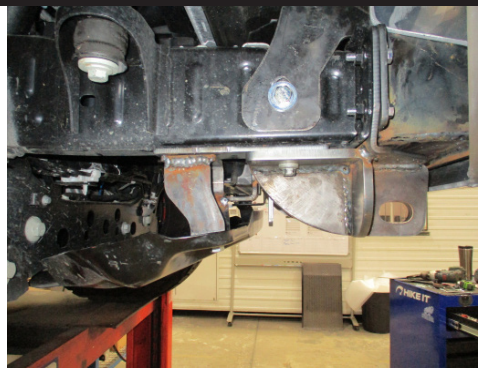

Stage 21

- On front of mount, align holes and fit M8 x 40mm bolts, M8 large flat washers and M8 spring washers where captive nuts are used on end of chassis rail, For other holes use M8 x 40mm bolts, large flat washers, spring washers and nuts. Finger tighten only.
- Align mounts and recovery hooks. Ensure intercooler is mounted correctly.
- Tighten all bolts.

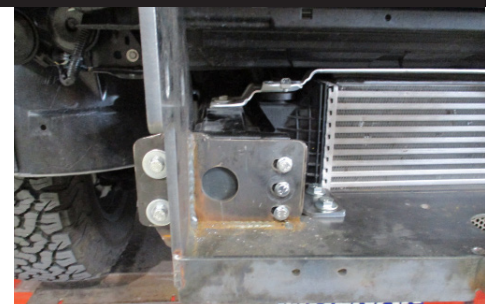

Ford Ranger 5-2022 on

Stage 22

- If fitting, install winch as per manufacturers instructions
- For Warn winches, a control box mount has been provided to mount to the drivers side of the vehicle using two (2) M6 x 25 bolts, flat washers and nyloc nuts.

Stage 23

- Remove sonar/parking sensor harness from bumper.
- Place harness and parking sensors into protection bar.
- Secure harness into protection bar using zip ties provided.



Stage 24

- Rotate parking sensor mount to suit direction parking sensor was removed from vehicle. Ensure silicon ring is attached to front of sensor. With parking sensor in correct direction, gently place into parking sensor mount with locating pins ratcheting into holding lugs. Push only until front of sensor is aligned with front of parking sensor mount. Silicon seat on parking sensor should seat loosely into front opening.
- Secure with zip ties. do not over tighten as this may cause sensor to go off.

EDF185SY

Stage 25

- Remove fog lights from bumper three (3) T25 Torx screws.
- Fit lights into protection bar using M6 x 25mm bolts, M6 flat washers and M6 nyloc nuts.
- Reconnect parking sensors and fog lights.

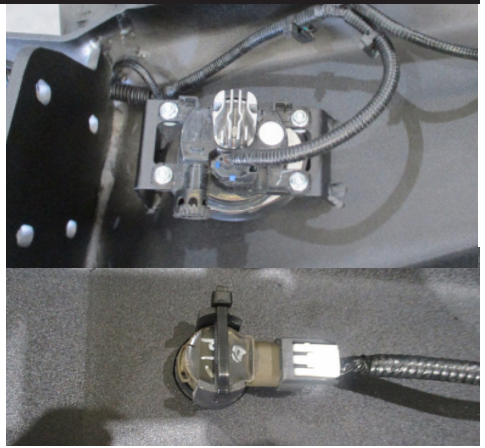

Stage 26

- Using tin snips or similar, trim lower section from sonar mount.
- Caution needs to be taken to not damage the sonar unit. If you do not feel confident, remove the sonar unit from the mount.

Blow filings clear and treat all exposed metal with a rust inhibitor

- Align and fit sonar to channel using M6 x 25mm bolt, M6 flat washer and M6 nyloc nuts.

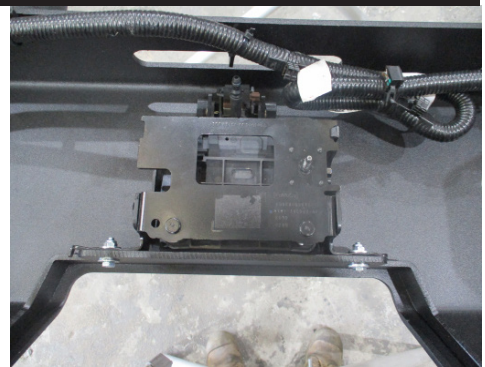

Stage 27

- Place camera into housing, lock into place with rear bracket. Secure camera into rear of protection bar using mounting brackets and 8-10 X 12 self drilling screws. **Do not over tighten.**

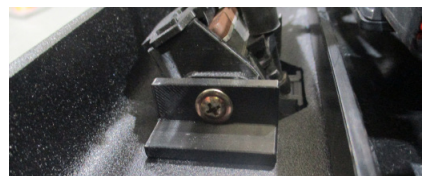

Ford Ranger 5-2022 on

Stage 28

- Attach 6mm clip lock trim (supplied) to top of ECB protection bar. NOTE: Trim off lower edge on an angle so trim will sit flush with end of protection bar.

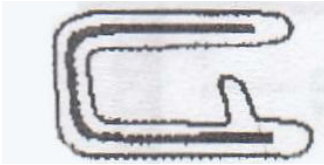

Stage 29

- Mask area to be trimmed to avoid any excess damage.
- Trim bumper using template provided with hacksaw or jigsaw.
- CAUTION: Double check cut line before trimming bumper.
- Place 3mm clip lock trim on cut edge. Where flare meets bumper remove a small section of clip lock from the rear and continue on outside of flare.



Stage 30

- Refit bumper in reverse as per steps 2 to 10.
- Do not install top grille cover at this time.



EDF185SY

Stage 31

- Fit protection bar to vehicle using M12 x 1.75 x 40mm bolts, M12 flat washers, M12 spring washers and M12 x 1.75 nuts.
- Align protection bar with vehicle and tighten all bolts.



Stage 32

- Connect fog lights, indi/park/DRL, camera, camera washer, sonar and parking sensors.
- Refit top grille cover.
- Hold number plate bracket in position, mark and drill 6mm mounting holes into protection bar.
- Install number plate bracket onto front of protection bar using two M5 x 20 screws, flat washers and nuloc nuts. Align and tighten all screws

Stage 33

- Fit side underbelly guards using M6 x 25mm bolts, M6 flat washers and M6 nuts. NOTE: two inner holes use M6 nuts on wire.
- Trim inner plastic guards to underbelly guards and place to behind underbelly guard.
- Refit underbelly guard, front holes use M10 x 1.5 x 30mm bolts, flat washer and spring washer (supplied).



Ford Ranger 5-2022 on

Stage 34

- Reconnect battery and check all safety features are working correctly.
- Ensure these instructions are left with the vehicle owner and/or operator.

Final Checks

Ensure Number Plate is Clearly Visible

Note: When fitting/refitting the licence plate to the vehicle, ensure there is no obstruction to licence plate vision in accordance with local authorities. If required relocate licence plate to an alternate location.

Further VFPS Notes

1. Do not attach VFPS to the vehicle using anchorages not intended for this purpose (e.g. engine mounting bolts).
2. Do not use this product for any vehicle make or model, other than those specified by the VFPS manufacturer.
3. Do not remove the plaque or label from the VFPS.
4. Do not modify the structure of the VFPS in any way.
5. No accessory or fitment should project forward of the VFPS forward profile.
6. **Ensure these instructions are left with the vehicle owner and/or operator.**

Important Information

Periodically check bolts and nuts for correct tightness, especially if traveling on rough roads.

Installation Kit

Installation Kit

1 - Winch mount	10 - M8 x 40mm bolts
1 - Pair recovery hooks	10 - 5/16 x 1 1/4 flat washers
1 - Winch control box mount	10 - M8 flat washers
2 - 8mm spacer plates	10 - M8 spring washers
4 - Three hole washers	4 - M8 nuts
4 - 12mm hole, 3mm steel washers	20 - M6 x 25mm bolts
1 - Center underbody guard	40 - M6 flat washers
1 - Pair side underbody guards	20 - M6 nyloc nuts
1 - Camera mounting kit	4 - M6 flange nut on 300mm wire
1 - Number plate hinge bracket	5 - M5 x 20mm Pan head screws
2 - M12 x 1.75 x 120mm bolts	10 - M5 flat washers
8 - M12 x 1.75 x 40mm bolts	5 - M5 nyloc nuts
20 - M12 flat washers	2 - 8-18 x 12 self drilling screws
10 - M12 spring washers	2 - Bumper light trims
10 - M12 x 1.75 nuts	6 - Parking sensor housings (fitted to bar)
2 - M10 x 1.5 x 30mm bolts	1 - 2450 length 6mm clip lock
2 - M10 flat washers	2 - 350mm lengths 3mm clip lock
2 - M10 spring washers	10 - 150mm zip ties

Finished Product



Warranty Registration

Contact Details

Name: _____

Address: _____

Product: **EDF185SY**

Email: _____

Phone: _____

Work Order Number: _____

You can find this on the silver label
of your ECB product.

By submitting this registration you automatically subscribe to ECB's mail outs.
You can unsubscribe at any time.

Register Online

For online registration please go online to www.ecb.com.au/warranty-registration
If you have any questions please contact our national office on 1800 069 145 or
www.ecb.com.au.

Or Post To:

PO Box 122, Margate, QLD 4019



PN: EDF185SY
Please post to: PO Box 122,
Margate QLD 4019

Notes

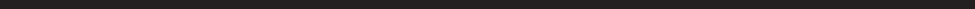

A series of 18 horizontal lines spaced evenly down the page, providing a template for handwritten notes.

 Full Name

 Date

REPLACES: N/A
REVISED: 30.05.23

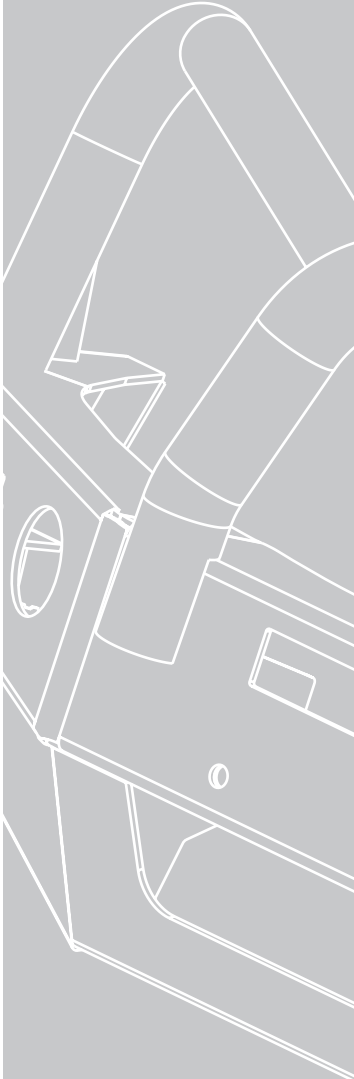

Safer Lighter Stronger

1800 069 145
www.ecb.com.au

29 Snook St, Clontarf QLD 4019
PO Box 122, Margate QLD 4019