



**WORLD'S BEST
ALLOY BULLBARS**

**Lighter
Stronger
Better!**

**Strongest Built
Australian Made
Lifetime Warranty**

PN:BN113SY



Fitting Guide & Owners Manual

NISSAN X-TRAIL

2022 ON

Big Tube Bar with Bumper Lights
VEHICLE FRONTAL PROTECTION SYSTEM (VFPS)
FOR AIR BAG & ADR COMPLIANT VEHICLES

Index

Pages 3-5

ECB's Benefits
Product Care

Pages 6-7

Stage 1 - Vehicle Testing and Preparation
Stage 2 - Radiator Cover
Stage 3 - Lower guards
Stage 4 - Outer flare
Stage 5 - Disconnect harness
Stage 6 - Remove grille

Pages 8-9

Stage 7 to 8 - Bumper removal
Stage 9 - Plastic support cover
Stage 10 - Head lights
Stage 11 - Shutter
Stage 12 - Sonar, oil cooler ,horn

Pages 10-11

Stage 13 - Shutter
Stage 14 - Bumper support rail
Stage 15 - Support bracket
Stage 16 - Support bracket
Stage 17 - Mount fitment
Stage 18 - Sonar,oil cooler, horn

Pages 12-13

Stage 19 - Heat sensor
Stage 20 - Parking sensors
Stage 21 - Fog lights
Stage 22 - Trim bumper grille
Stage 23 - Refit bumper
Stage 24 - Clip lock

Pages 14-15

Stage 25 - Camera
Stage 26 - Fit protection bar
Stage 27 - Bumper lights
Stage 28 - Reconnect battery
Stage 29 - Tow hooks

Pages 16-17

Final Checks & Fitting Kit
Finished Product

Pages 18-19

Warranty Registration

The Features of ECB

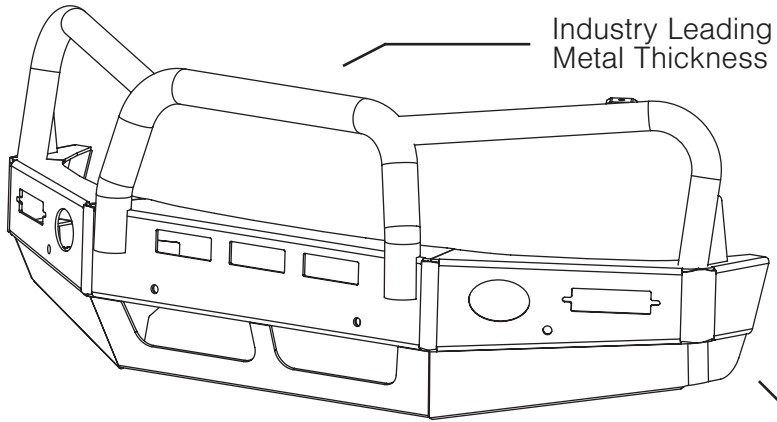

Industry Leading
Metal Thickness

6mm Thick
Hi-Tensile Alloy

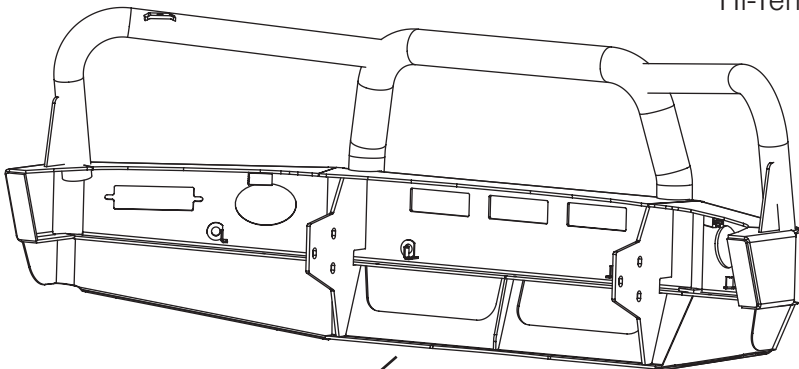

Unmatched
Strength

Fully Welded
Construction

ECB's Benefits

Built to Perform - Not to a Price

ECB are proud to claim that their channels are not jigsaw puzzles that are bolted together, or even multiple sections welded together. Where any welding is required, it is done to the highest standards by qualified welders, not machines.

Anti-Corrosive Nature of Alloy

The composition of ECB's alloy has a very high resistance to corrosion. Rust not only looks unappealing but greatly reduces the strength of the metal. Rust can and will weaken the structural integrity of a steel bullbar effectively rendering it useless over time.

Australian Made

Established in 1971, we utilise over 46 years of experience designing, engineering and building products in Australia to suit Australian conditions. We can ensure the best quality controls and help support the local economy and employ over 90 proud Australians.

Weight Saving Benefits

An ECB alloy bullbar is typically half the weight of a steel bullbar. Unnecessary suspension upgrades are not required. The reduced weight also contributes to increased fuel economy and less wear and tear on tyres, suspension and braking components.

Welds That Work

ECB uses only the strongest welds and welding techniques to ensure every product is as structurally sound as possible. MIG (Metal Inert Gas) welding techniques are employed ensuring the welds are as thick as the thickest section of alloy's being joined together.

Lifetime Warranty

ECB provide a lifetime warranty and consumer guarantee on all of our manufactured products. This guarantee highlights the confidence in our ability and provides complete peace of mind for your purchase for the lifetime you own your vehicle.

Product Care

Polished Products

Being a premium mirror polished finish, regular maintenance will be required to keep that iconic ECB shine. We recommend using our own brand of Aluminium Polish. This formula has been tried and tested and in our opinion is the world's best standard.

Directions: Apply a small quantity of Aluminium Polish to a clean soft cloth and rub the metal surface. The longer the rubbing the brighter the surface becomes. Wipe off Aluminium Polish with clean soft cloth. Also suitable for motorised buffing machines.

Note: There are more specific details on the polish bottle. Please read before use.

Powdercoated Products

Our powdercoated finishes are very low maintenance, Infact there is actually very little you will ever need to do for this product. Just clean it as you would your car and it will stay looking good as new.

ECB Aluminium Polish

When you're looking for that showroom finish look for your polished automotive products, you can depend on the no compromise quality of East Coast Bullbars Aluminium Polish. This specifically designed product is the best polish available and we guarantee that this \$#!+ works. With over 40 years of manufacturing polished alloy products we have trialed a large range of different polishes on the market and believe without a doubt that nothing beats the finish quality of East Coast Bullbars Aluminium Polish.

East Coast Bullbars Aluminium Polish is excellent for use by hand and is ideal for polished bullbars, nudge bar and stainless steel products. This polish will clean, polish and protect your product from the elements whilst bringing your products back to that showroom finish look.



BN113SY

Stage 1

- Test drive vehicle to ensure all driver assists are correctly working and to gauge effectiveness. Park on a flat level surface.
- Apply parking brake and lift bonnet.
- Unwrap ECB Protection bar and disconnect mounts. Discard bolts.
- Ensure these instructions are left with the vehicle owner and/or operator.



DISCONNECT BATTERY

Ensure these instructions are left with the vehicle owner and/or operator.

Stage 2

- Remove top radiator cover, ten (10) clips.



Stage 3

- Underside remove six (6) push pull clips and Seven (7) T20 Torx screws per side.
- Remove outer lower side under guards.



NISSAN X-TRAIL 2022

Stage 4

- On inner lower guard, remove one (1) T20 Torx screw (per side), two (2) push pull clips half way up inner guard.
- Pull inner guard away from guard, reach in and unclip three (3) retaining clips to release outer flare.
- Carefully unclip outer flare from guard back two clips past guard bumper join.
- Remove one (1)10mm head screw per side from behind flare at guard join.



Stage 5

- Disconnect fog lights connection on passenger side.
- On drivers side in engine bay near window washer bottle, disconnect parking sensors.



Stage 6

- Remove centre grille, release two(2) clips each side on top of grille, release ten (10) clips by pushing clip from outside to in, pull grille forward.
- Disconnect camera from grille and remove, two (2) T20 Torx screws.

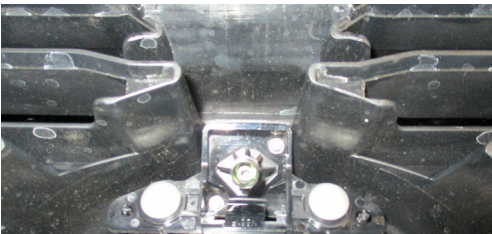
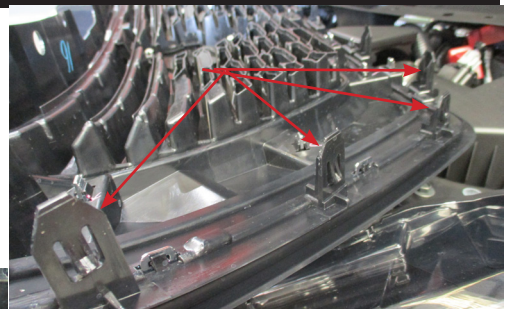

BN113SY

Stage 7

- Top of bumper between head lights remove two (2) push pull clips per side.



Stage 8

- Gently pull bumper away from guard and under lights.
- Remove bumper.



Stage 9

- Remove plastic bumper reinforcement cover. one built in clip each side of bumper support.
- Remove foam support.



NISSAN X-TRAIL 2022

Stage 10

Remove headlights from car, disconnect harness from rear of light.

Remove five (5) 10mm head bolts, three on top of light , two on outside of light.

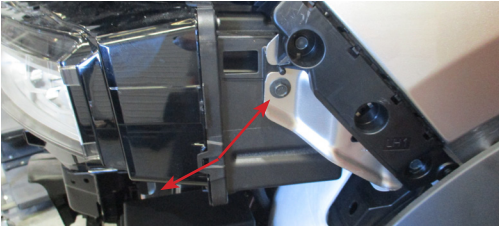
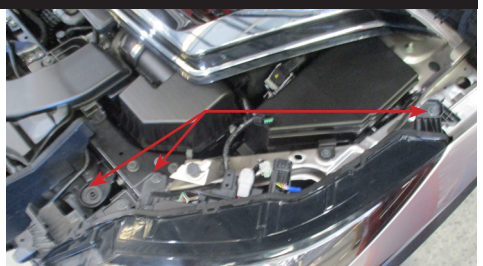

Stage 11

- Disconnet shutter, connection is on the underside, also disconnect heat sensor and remove.
- Remove two push pull clips either side of shutter.

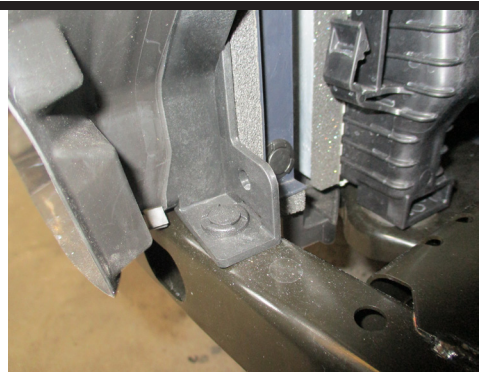

Stage 12

- Remove sonar unit, oil cooler and horn from support rail four (4) 10mm head bolts.
- Secure oil cooler so it is supported until refitment.
- Unclip harnesses from support rail.



BN113SY

Stage 13

- Remove shutter from support rail two 10mm nuts. Remove and disconnect heat sensor.
- Place shutter on ECB steel mount , trim upper rubber flap to suite steel mount , secure to mount using M6x25mm bolts,M6 flat washers ,M6 spring washers and M6 nuts.



Stage 14

- Remove support rail four, (4) 16mm head bolts (per side).



Stage 15

- Fit ECB steel mount to front of chassis using M10 x 1.25 x 40mm bolts, flat washers and spring washers. Align and tighten bolts.
- Using mount as a guide drill 8mm hole in front of chassis rail.
- Remove ECB mount, **Blow filings clear and treat all exposed metal with a rust inhibitor**

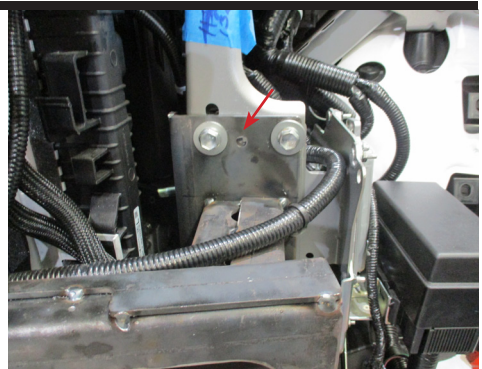

NISSAN X-TRAIL 2022

Stage 16

- Secure front of support bracket to chassis rail, using M8 x 1.5 x 30mm bolts, flat washers, spring washers and M8 x 1.5 nut.
- Using mount as a guide drill two 8mm holes into top of rail. **Blow filings clear and treat all exposed metal with a rust inhibitor**
- Install one M8 x 1.5 x 30 bolt, flat washer, spring washer and nut into front hole and one M8 x 1.5 x 30 bolt, flat washer, spring washer and M8 nut on wire for rear hole. Align all holes and tighten all bolts.



Stage 17

- Refit ECB mount back to rail secure with M10 x 1.25 x 40mm bolts, flat washers and spring washers.
- Align mount and tighten all bolts.

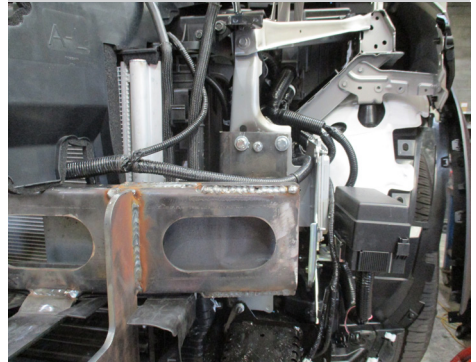

Stage 18

- Refit sonar, oil cooler, horn, and wiring harness using M6 x 25mm bolts, flat washers and spring washers and zip tie wiring to steel mount
- Remove grille supports from bumper support and relocate to ECB mount, using M6 Bolts, flat washers and spring washers.



BN113SY

Stage 19

- Relocate heat sensor to innerside of steel mount using 200mm fig tree zip ties.

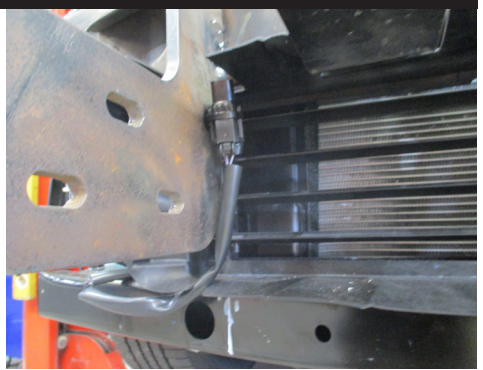

Stage 20

- Remove parking sensors from bumper, taking note direction of sensors as they are to be fitted in same direction in protection bar.
- Extend parking sensors harness, 200mm with three core wire.
- Join with solder joiners (supplied).
- **Place any exposed wiring in convoluted tubing supplied.**

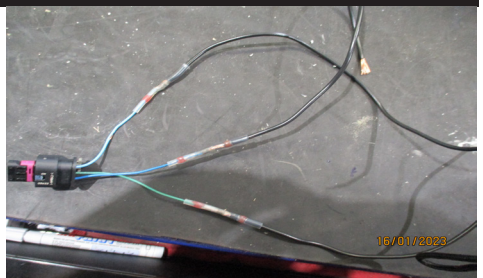

Stage 21

- Remove fog lights from bumper, three (3) T25 Torx screws.
- Install ECB Quick click connectors onto original wiring.

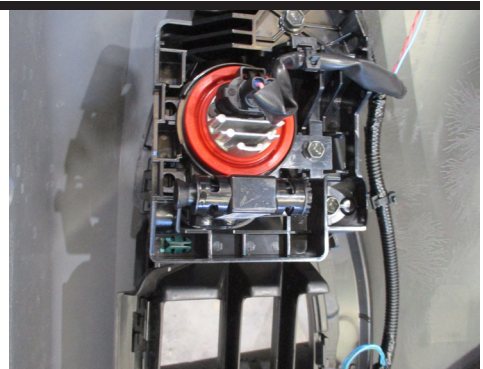

NISSAN X-TRAIL 2022

Stage 22

- Using measurements from mounts on vehicle. Trim lower air vent of bumper to allow protrusion of mounts



Stage 23

- Refit lights and bumper, in reverse of steps 2 to 10.
- Have all sensor, camera and fog light wiring protruding to the outside of bumper for connection.



Stage 24

- Attach 6mm clip lock trim (supplied) to top of ECB protection bar. NOTE: Trim off lower edge on an angle so trim will sit flush with end of protection bar.



BN113SY

Stage 25

- Install camera into protection bar to rear of mounting bracket.
- Align camera evenly in channel hole and secure with 10mm self drilling screws.
- Fit parking sensors to housings in protection bar, ensuring they are facing same direction as per bumper. Secure sensor in housing with 150mm zip tie, do not over tighten this may cause sensor to go off.

Note: Zip tie is here for added security rather than to hold the sensor in place. Gently tightening is recommended.



Stage 26

- Fit protection bar to steel mount using M10 x 1.25 x 40mm bolts, flat washers, spring washers and M10 x 1.25 nuts.
- Align protection bar with vehicle and tighten all bolts.
- Connect parking sensors and camera.



Stage 27

- Connect fog light to the quick click harness previously installed.
- Place M6 x 20 bolts, spring washers (supplied) through fog light mount from inside and attach nut to top. Slide assembly into light mount in Protection bar and centralize light to hole. TIGHTEN FIRM ONLY.
- Install fog light surrounds (supplied) to fog light openings.

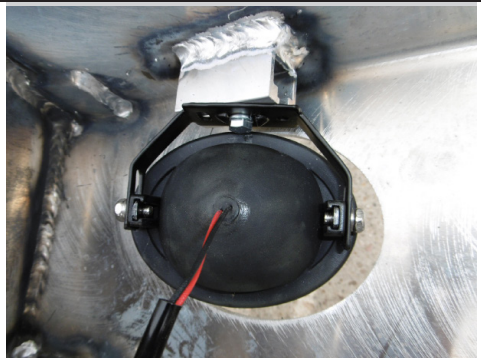

NISSAN X- TRAIL 2022

Stage 28

RECONNECT BATTERY

- Test all electrics and safety features are working correctly.
-

CAUTION WHEN TOWING USE BOTH TOW POINTS ON STEEL MOUNT.

Final Checks

Ensure Number Plate is Clearly Visible

Note: When fitting/refitting the licence plate to the vehicle, ensure there is no obstruction to licence plate vision in accordance with local authorities. If required relocate licence plate to an alternate location.

Further VFPS Notes

1. Do not attach VFPS to the vehicle using anchorages not intended for this purpose (e.g. engine mounting bolts).
2. Do not use this product for any vehicle make or model, other than those specified by the VFPS manufacturer.
3. Do not remove the plaque or label from the VFPS.
4. Do not modify the structure of the VFPS in any way.
5. No accessory or fitment should project forward of the VFPS forward profile.
6. **Insure these instructions are left with the vehicle owner and/or operator.**

Important Information

Periodically check bolts and nuts for correct tightness, especially if traveling on rough roads.

Fitting Kit

Fitting Kit

1 - ECB steel mount	3 - M6 Nyloc nuts
1 - Pair Steel support brackets left and right	2 - M6 Nuts
14 - M10 x 1.25 x 40mm Bolts	2 - 10mm Self drilling screws
20 - M10 Flat washers	1 - 2300 Length 6mm clip lock
14 - M10 Spring washers	2 - 700 Length 6mm clip lock
6 - M10 x 1.25 Nuts	1 - Bumper lights
6 - M8 x 1.5 x 30mm Bolts	1 - Quick click fog harness (IC10D40S1004ECBH)
10 - M8 Flat washers	2 - Bumper light trims
6 - M8 Spring washers	4 - 200mm Lengths 3 core wire
4 - M8 x 1.5 Nuts	24 - Solder joiners
2 - M8 x 1.5 Nuts on 300mm Wire	4 - 250mm Lengths convoluted tube
9 - M6 x 25mm Bolts	1 - 200mm Zip tie with fig tree
2 - M6 x 20 Bolts	4 - 300mm Zip ties
9 - M6 Flat washers	4 - 150mm zip ties
11 - M6 Spring washers	

Finished Product



Warranty Registration

Contact Details

Name: _____

Address: _____

Product: **BN113SY**

Email: _____

Phone: _____

Work Order Number: _____

You Can find this on the silver label
of your ECB product.

By submitting this registration you automatically subscribe to ECB's mail outs. You
can unsubscribe at any time.

Or Register Online

For online registration please go online to www.ecb.com.au/warranty-registration
If you have any questions please contact our national office on 1800 069 145 or
www.ecb.com.au.



REPLACES: 00.00.00

REVISED: 17.05.23

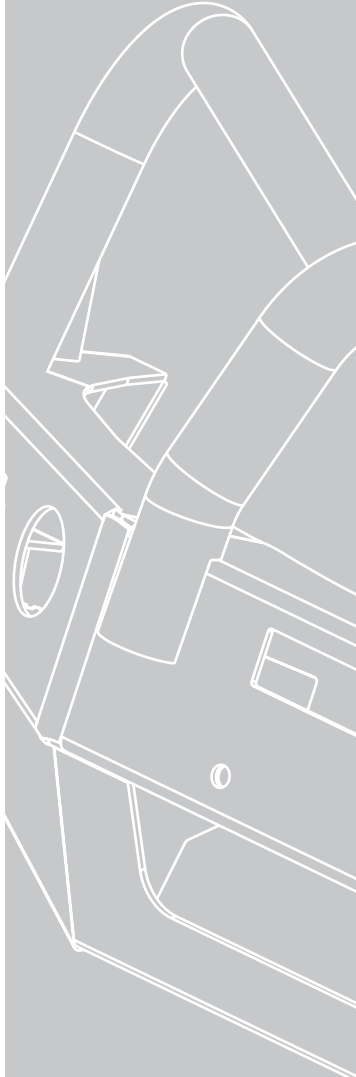

1800 069 145
www.ecb.com.au

Strongest Built Australian Made Lifetime Warranty

29 Snook St, Clontarf QLD 4019
PO Box 122, Margate QLD 4019