



PN:B3HY5002SY



Fitting Guide & Owners Manual

HYUNDAI MIGHTY

01/2014 ON

BIG TUBE BULLBAR
VEHICLE FRONTAL PROTECTION SYSTEM (VFPS)
FOR AIR BAG & ADR COMPLIANT VEHICLES

Index

Pages 3-5

ECB's Benefits
Product Care

Pages 6-7

Stage 1 - Vehicle Testing and Preparation
Stage 2 - Disconnect Bumper Lights
Stage 3 - Remove Bumper
Stage 4 - Tow Hook
Stage 5 to 6 - Steel Mounting

Pages 8-9

Stage 7 - Bumper Light Installation
Stage 8 - Fit Protection Bar
Stage 9 - Connect Lights
Stage 10 - Eye Bolts
Stage 11 - Tilt Stickers

Pages 10-11

Final Checks & Fitting Kit
Finished Product

Pages 12-13

Warranty Registration

Pages 14-15

Notes

The Features of ECB

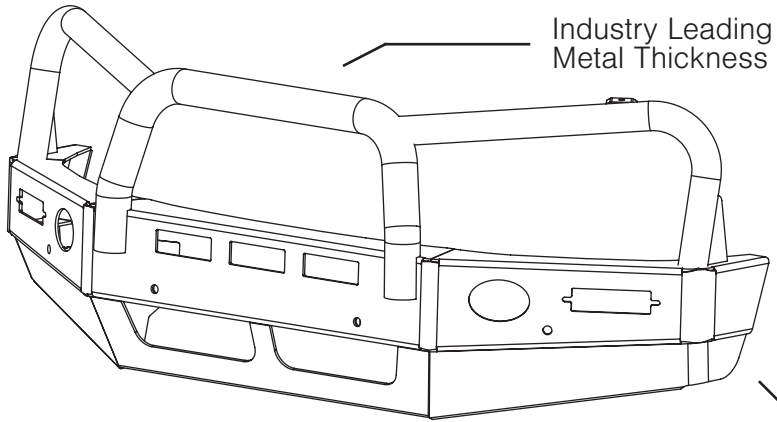

Industry Leading
Metal Thickness

6mm Thick
Hi-Tensile Alloy

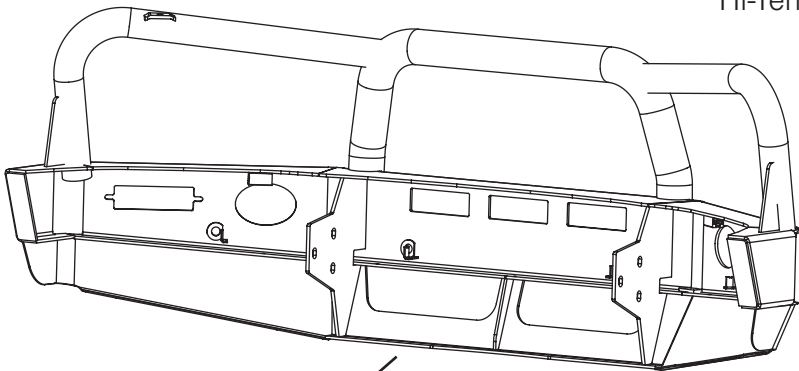

Unmatched
Strength

Fully Welded
Construction

ECB's Benefits

Built to Perform - Not to a Price

ECB are proud to claim that their channels are not jigsaw puzzles that are bolted together, or even multiple sections welded together. Where any welding is required, it is done to the highest standards by qualified welders, not machines.

Anti-Corrosive Nature of Alloy

The composition of ECB's alloy has a very high resistance to corrosion. Rust not only looks unappealing but greatly reduces the strength of the metal. Rust can and will weaken the structural integrity of a steel bullbar effectively rendering it useless over time.

Australian Made

Established in 1971, we utilise decades of experience designing, engineering and building products in Australia to suit Australian conditions. We can ensure the best quality controls and help support the local economy and employ over 90 proud Australians.

Weight Saving Benefits

An ECB alloy bullbar is typically half the weight of a steel bullbar. Unnecessary suspension upgrades are not required. The reduced weight also contributes to increased fuel economy and less wear and tear on tyres, suspension and braking components.

Welds That Work

ECB uses only the strongest welds and welding techniques to ensure every product is as structurally sound as possible. MIG (Metal Inert Gas) welding techniques are employed ensuring the welds are as thick as the thickest section of alloy's being joined together.

Lifetime Warranty

ECB provide a lifetime warranty and consumer guarantee on all of our manufactured products. This guarantee highlights the confidence in our ability and provides complete peace of mind for your purchase for the lifetime you own your vehicle.

Product Care

Polished Products

Being a premium mirror polished finish, regular maintenance will be required to keep that iconic ECB shine. We recommend using our own brand of Aluminium Polish. This formula has been tried and tested and in our opinion is the world's best standard.

Directions: Apply a small quantity of Aluminium Polish to a clean soft cloth and rub the metal surface. The longer the rubbing the brighter the surface becomes. Wipe off Aluminium Polish with clean soft cloth. Also suitable for motorised buffing machines.

Note: There are more specific details on the polish bottle. Please read before use.

Powdercoated Products

Our powdercoated finishes are very low maintenance. Infact there is actually very little you will ever need to do for this product. Just clean it as you would your car and it will stay looking good as new.

ECB Aluminium Polish

When you're looking for that showroom finish look for your polished automotive products, you can depend on the no compromise quality of East Coast Bullbars Aluminium Polish. This specifically designed product is the best polish available and we guarantee that this \$#!+ works. Within our decades of manufacturing polished alloy products we have trialed a large range of different polishes on the market and believe without a doubt that nothing beats the finish quality of East Coast Bullbars Aluminium Polish.

East Coast Bullbars Aluminium Polish is excellent for use by hand and is ideal for polished bullbars, nudge bar and stainless steel products. This polish will clean, polish and protect your product from the elements whilst bringing your products back to that showroom finish look.



B3HN5002SY

Stage 1

- Test drive vehicle to ensure all driver assists are correctly working and to gauge effectiveness. Park on a flat level surface.
- Apply parking brake.
- Unwrap ECB Protection bar and disconnect mounts. Discard bolts.
- Ensure these instructions are left with the vehicle owner and/or operator.



Stage 2

- Disconnect fog lights

Passenger side shown



Stage 3

- Remove three (3) 17mm head bolts from bumper (per side). Two (2) from top and one (1) from bottom.
- Remove bumper.



HYUNDAI MIGHTY

Stage 4

- Remove tow hook from drivers side rail, two (2) 17mm head bolts.



Stage 5

- Install steel mount onto ends of chassis rail. Spacers are included in the kit to allow adjustment to the cabin.
- Measure mount to cabin to assess whether spacers are required.
- NOTE: Spacers at top adjust the height of the mount. If no adjustment is required, place lower spacers in both sides.



Stage 6

- Fit mount using six (6) M12 x 1.25 x 40 bolts (per side), flat washers and nyloc nuts. Place washer plate to outside of side bolts. Top and bottom bolts have captive nuts in the chassis rail.
- Measure from chassis rail to front of mount to align level to front of the vehicle. Development vehicle was set 160mm at inside of mount.
- Nip tighten front underside bolt first. Using a level on the front of the mount, manipulate the mount so it is vertical. Tighten top bolts. Complete tighten lower bolts, then side bolts.

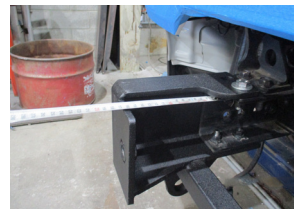

B3HN5002SY

Stage 7

- Remove lights from bumper, four (4) 12mm head bolts per side.
- Place lights into rear of Protection bar using four (4) M6 x 25 bolts, flat washers and nyloc nuts.
- Align with opening on front of protection bar and tighten all bolts.

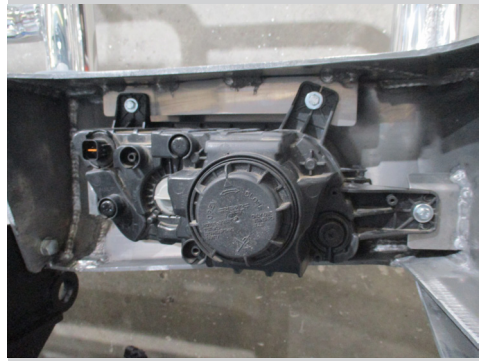

Stage 8

- Loosely install Protection bar to mounts using eyebolts, large washers and nylon washers in front of product. This will give ability to move bar around whilst installing lower pivot bolts.
- Install lower M14 x 1.5 x 70 bolts, flat washers and nyloc nuts into pivot point.
- Tighten pivot point only till nut touches alloy. Do NOT tighten past this point as it WILL damage the product and could cause the product to be misaligned.
- Carefully open doors to ensure they do not hit bar at fully open. Re-adjust product if required.



Stage 9

- Remove eyebolts and gently drop protection bar forward.
- Connect lights.



HYUNDAI MIGHTY

Stage 10

- Lift protection bar back into position and refit eyebolts to front of product.
- Firmly tighten eyebolts.



Stage 11

- Install tilt sticker to rear of cabin above tilt locking mechanism.
- Clean area visible to the driver on the dash or door panel and install tilt sticker.

Final Checks & Installation Kit

Ensure Number Plate is Clearly Visible

Note: When fitting/refitting the licence plate to the vehicle, ensure there is no obstruction to licence plate vision in accordance with local authorities. If required relocate licence plate to an alternate location.

Further VFPS Notes

1. Do not attach VFPS to the vehicle using anchorages not intended for this purpose (e.g. engine mounting bolts).
2. Do not use this product for any vehicle make or model, other than those specified by the VFPS manufacturer.
3. Do not remove the plaque or label from the VFPS.
4. Do not modify the structure of the VFPS in any way.
5. No accessory or fitment should project forward of the VFPS forward profile.
6. **Ensure these instructions are left with the vehicle owner and/or operator.**

Important Information

Periodically check bolts and nuts for correct tightness, especially if traveling on rough roads.

Installation Kit

1 - Steel mounting bracket	4 - M14 Flat washers
2 - 5mm steel spacer plates	2 - M14 x 1.5 nyloc nuts
2 - 5mm spacer plates	12 - M12 x 1.25 x 40 bolts
2 - 6mm steel washer plates	16 - M12 flat washers
2 - 3/4 eyebolts	4 - M12 x 1.25 nyloc nuts
2 - M20 x 37 x 2 flat washer	8 - M6 x 25 bolts
2 - M20 X 37 X 3mm nylon washer	16 - M6 flat washers
2 - M14 x 1.5 x 70 bolts	8 - M6 nyloc nuts

Finished Product



Warranty Registration

Contact Details

Name: _____

Address: _____

Product: **B3HY5002SY**

Email: _____

Phone: _____

Work Order Number: _____

You can find this on the silver label
of your ECB product.

By submitting this registration you automatically subscribe to ECB's mail outs.
You can unsubscribe at any time.

Register Online

For online registration please go online to www.ecb.com.au/warranty-registration
If you have any questions please contact our national office on 1800 069 145 or
www.ecb.com.au.

Or Post To:

PO Box 122, Margate, QLD 4019



PN: B3HY5002SY
Please post to: PO Box 122,
Margate QLD 4019

Notes

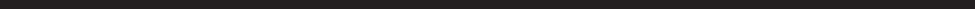

A series of 18 horizontal lines for writing notes, evenly spaced and extending across most of the page width.

 Full Name

 Date

REPLACES: N/A
REVISED: 11.09.23

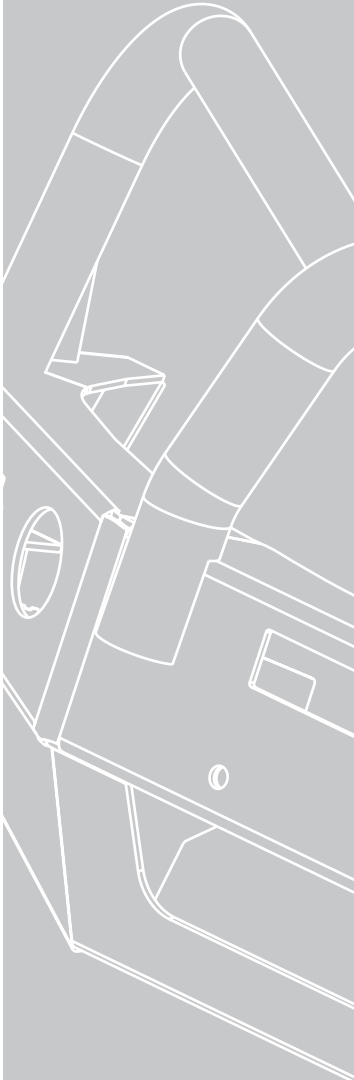

Safer Lighter Stronger

1800 069 145
www.ecb.com.au

29 Snook St, Clontarf QLD 4019
PO Box 122, Margate QLD 4019