



BULLBAR FITTING INSTRUCTIONS

TO SUIT: HINO 300 SERIES 036A WIDE CAB 2011+

PART NUMBER: B3HN5318TSY

Step1.
Park the vehicle on level ground and apply the park brake.
Check installation hardware and read fitting instructions before commencing.



Step 2.
Disconnect fog light wiring connector from rear of bumper through cavity behind licence plate mount area.



Step 3.
Remove 6 bolts (3 per side) retaining the bumper.
Retain the bumper discard the bolts.



Step 4.

Lay bumper face down on a blanket and disconnect fog light wiring connectors. Remove fog lights from bumper by releasing 4 x Phillips head screws per light. Put lights in a safe place and discard screws. Retain bumper.

Note: Drivers side pictured

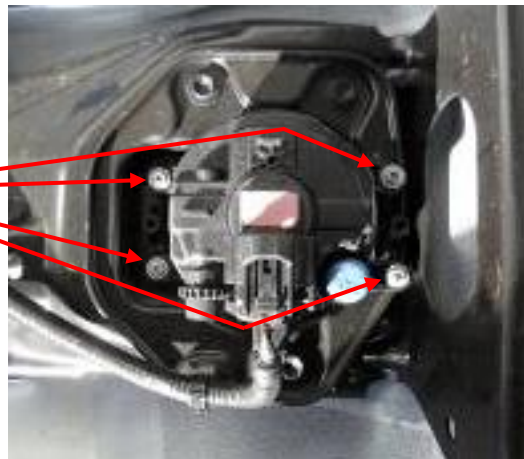

Step 5.

Unclip fog lights wiring loom from rear of bumper. Retain wiring loom. Discard bumper.



Step 6.

Disconnect parker light wiring connector and indicator light wiring connector from headlights, each side of vehicle. Connect patch harness provided to light and original harness, each side of vehicle.

Parker connector
Indicator connector
Patch harness



Step 7.

Remove and retain M6 bolt from lower outer corner of headlight, each side of the vehicle.

M6 bolt

Note: Drivers side pictured



Step 8.

Secure tab on infill strip to lower outer hole in headlight using bolt previously removed.

Tighten bolt and repeat for the other side.

Infill strip

Note: Drivers side pictured



Step 9.

Bend infill strip around under headlight and secure using 1 - 3/16" x 3/4" Screw and nyloc nut through inner headlight aim adjustment hole.

Lightly tighten screw, repeat for the other side.



Step 10.

Remove tow hook from passengers side chassis.

Retain tow hook and fasteners.

Note: Passengers side pictured



Step 11.

Remove steel bullbar mount from bullbar and fit to the vehicle chassis, lightly fasten using

1 - M14 x 50mm bolt, spring and flat washer in captive nut on passengers side.

1 - 1/2" x 1/2" bolts, flat washers and nyloc nuts through chassis on drivers and passenger side.

Refit tow hook using original bolts and 2 additional flat washers and 1 nut, tighten fully.

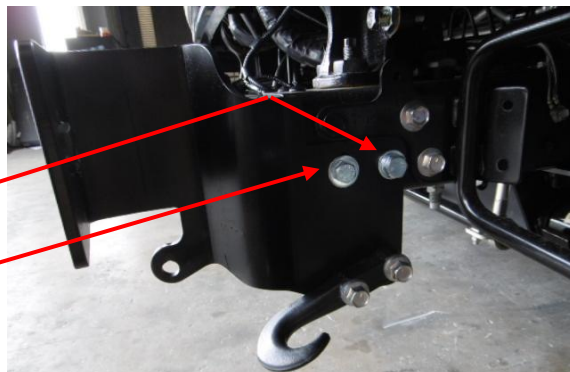

Step 12.
Lightly fasten the chassis mount front plates to captive nuts in front of chassis using 6 - M8 x 25 bolts and flat washers.

Note: Passengers side pictured

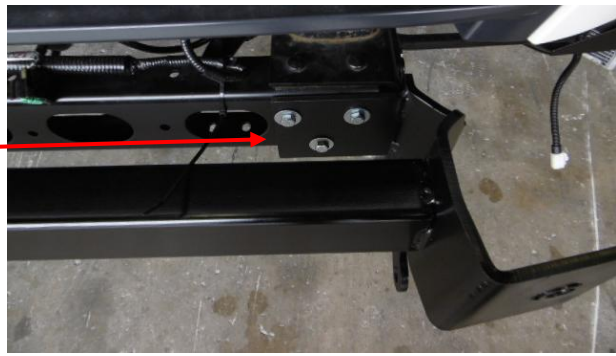

Step 13.
A 4mm spacer may need to be fitted to the front of the chassis on the drivers side between the front chassis and chassis mount plate to allow for vehicle chassis mis-alignment.

Note: Drivers side pictured

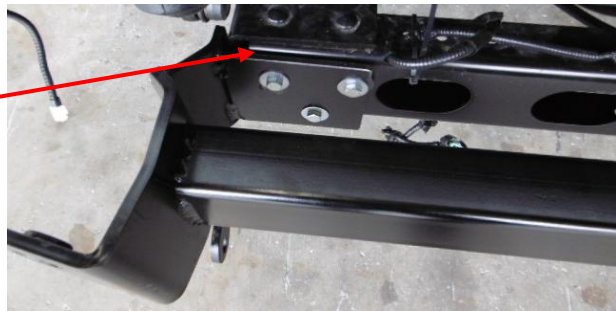

Step 14.
Lay bullbar face down on a blanket.
Fit fog light mount brackets supplied to fog lights using M6 x 20mm bolts and whiz lock nuts.
Fit fog lights to bullbar using 1" x 3/8" bolts, flat washers, spring washers and nuts.
Align lights in bullbar and tighten bolts.



Step 15.
Fit bullbar to mount loosely using 3/4" eye bolts with flat washers.

3/4" eye bolts



Note: Non Tow Pin bullbar shown

Step 16.

Align hinge bolt holes and fasten using 9/16" x 2 1/2" bolts, flat washers and nyloc nuts.

Tighten so nylon on nut engages on bolt and tabs on bullbar just start to pull in.
Fit indicators to the Bull bar.

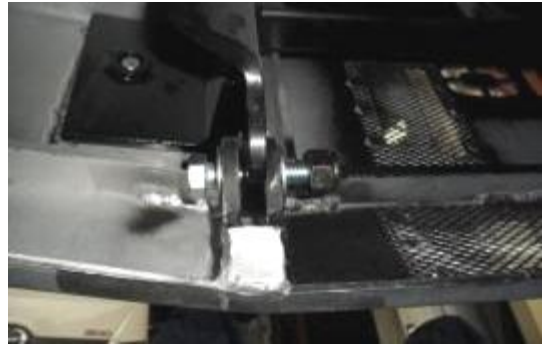

Step 17.

Tighten eye bolts.

Align bullbar with vehicle and tighten all mount bolts, Tighten front (M8) bolts last. Remove eye bolts and check bullbar tilt. Reconnect fog light wiring connectors and cable tie harness to steel mount. Connect parker/indicator connectors, adapters and check the operation of all lights.



Note: Non Tow Pin bullbar shown

Step 18.

Fit Tilt Bullbar Warning sticker to passengers side rear of cabin near tilt lever.



B3HN5318SY FITTING KIT

FITTED TO BULL BAR

- 1 - Bull Bar assembly
- 1 - Chassis Mount assembly (Must measure 822mm + inside)
- 2 - 3/4" Eye Bolts
- 2 - 3/4" Flat Washers
- 2 - 9/16" x 2-1/2" Hinge Bolts
- 2 - 9/16" Nyloc Nuts
- 4 - 9/16" Flat Washers

BULL BAR FITTING KIT







- 1 - Chassis mount spacer (4mm thick) (in Kit)
- 2 - 3/16" x 3/4" Grub screws
- 2 - 3/16" Nyloc nuts
- 6 - M8 x 1.25 x 25mm Bolts
- 6 - M8 Flat washers
- 2 - 1/2" x 1 1/2" Bolts
- 4 - 1/2" Flat washers
- 2 - 1/2" Nyloc nuts
- 1 - M14 x 1.5 X 50mm Bolt
- 1 - M14 Spring washer
- 3 - M14 Flat washers
- 1 - M14 x 1.5 Nut
- 4 - Cable ties
- 1 - Pair of IC 104 LED BL Park/Indicator assemblies (1 box)
- 2 - Patch Harnesses supplied (A36 ICH 036A)
- 2 - Patch Harness Adapters supplied
- 1 - Passengers side infill strip (36A) 2011+
- 1 - Drivers side infill strip (36A) 2011+
- 1 - Tilt Cab Warning Sticker

FOG LIGHT FITTING KIT

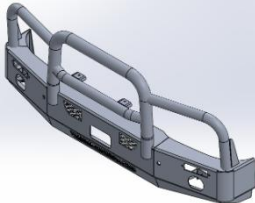
- 8 - M6 x 1.0 x 20mm Bolts
- 8 - M6 x 1.0 Whiz lock nuts
- 8 - M6 x 16 flat washes
- 4 - 3/8" x 1" UNC Bolts
- 4 - 3/8" x "1 x 16g Flat washers
- 4 - 3/8" Spring washers
- 4 - 3/8" UNC Nuts
- 4 - Fog Light mounting brackets
- 2 - Fog Light surrounds



1 Pair Infills 2011

 <p>1 - Bull Bar assembly</p>	 <p>1 - Chassis Mount assembly (rear view) (Must measure 822mm + inside)</p>	 <p>1 - Chassis mount spacer (4mm thick)</p>
 <p>Fog Light mounting brackets</p>	 <p>Washer plate 6MM (84 x 55mm, 2 slots, 18 x 25 & 16.3 x 25)</p>	 <p>LED fog bracket</p>



**Strongest Built
Australian Made
Lifetime Warranty**

DESPATCH CHECKLIST

B3HN5318TSY

HINO 300 SERIES 036A WIDE CAB 2011+

Work Order #	
Finish:	
Transport:	
Due Date:	

OC.....1 - Steel Chassis mount assembly. (Must measure 822mm + inside)

BK.....1 - Chassis mount spacer plate.

BK.....1 - Bolt Kit. (Including Drive light brackets)

OC..... 2 – IC 104 LED BL Indicator/Pk light assemblies supplied.

BK..... 2 - Plastic Drive Light Surrounds supplied.

OC..... 1 - Pair Infill panels supplied. (036A) 2011+

BK..... 2 - Patch Harnesses supplied. (ICH 036A).

BK..... 2 – Patch Harness Adapters supplied.

Fitted to Bar

OC.....2 - **ECB** Over-riders – 4 Screws fitted to each Over-rider.

OC..... 2 – 3/4" Eyebolts & Washers.

OC2 – 9/16" x 2-1/2" UNC Bolts, Flat washers and Nyloc nuts.

_____/_____
Wrapper's initials / Checker initials

	Is this product “the best it can be” Yes
	If NO fix before continuing

All parts checked and completed by:

Nut and bolts: _____ Date __ / __ / __

Order control: _____ Date __ / __ / __

Final wrap check: _____ Date __ / __ / __

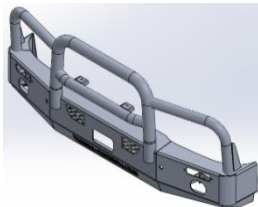

1 - Bull Bar assembly



Fog Light mounting brackets



1 pair of infills (2011)



1 - Chassis Mount assembly (rear view)
(Must measure 822mm + inside)



Washer plate 6MM (84 x 55mm, 2 slots, 18 x 25 & 16.3 x 25)



1 - Chassis mount spacer
(4mm thick)



LED fog bracket